

TECHNICAL SPECIFICATIONS

FD/FGE15-35(C)-E2

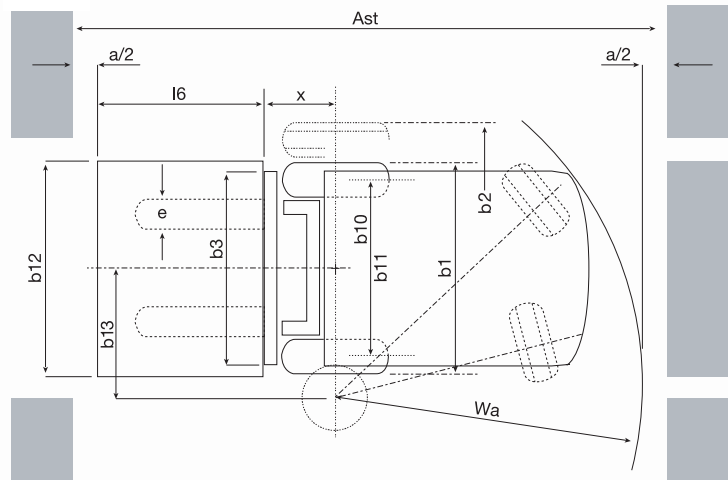

DIMENSIONS

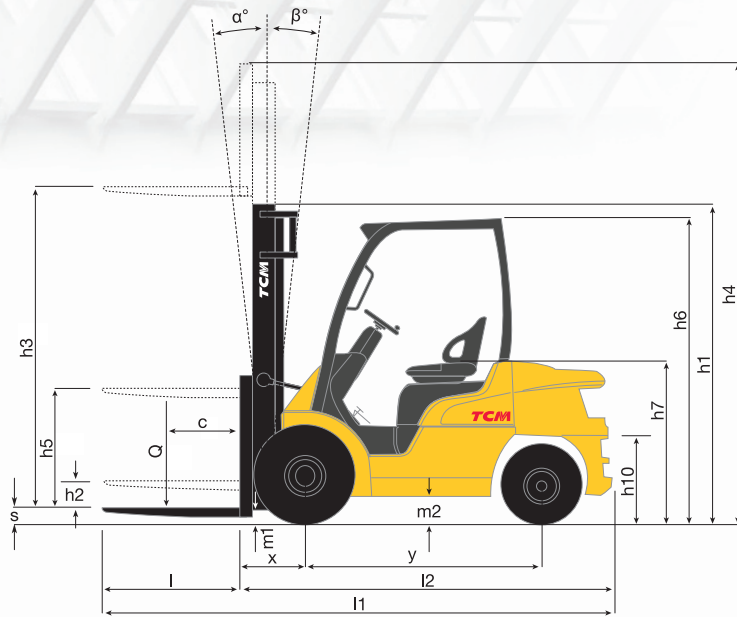

| TCM Forklifts | | | |
|----------------|----------------|----------------|----------------|
| FGE20-E2 | FGE25-E2 | FGE30-E2 | FGE35-E2 |
| LPG | LPG | LPG | LPG |
| Seated | Seated | Seated | Seated |
| 2000 | 2500 | 3000 | 3500 |
| 500 | 500 | 500 | 500 |
| 455 | 460 | 495 | 495 |
| 1600 | 1600 | 1700 | 1700 |
| 3300 | 3600 | 4240 | 4630 |
| 4600/670 | 5390/680 | 6470/770 | 7180/950 |
| 1410/1860 | 1390/2180 | 1710/2530 | 1630/3000 |
| SE / SE | SE / SE | SE / SE | SE / SE |
| 7,00-12-12PR | 7,00-12-12PR | 28x9-15-12PR | 250-15-12PR |
| 6,00-9-10PR | 6,00-9-10PR | 6,50-10-10PR | 6,50-10-10PR |
| 2x / 2 | 2x / 2 | 2x / 2 | 2x / 2 |
| 960 | 960 | 1060 | 1060 |
| 980 | 980 | 980 | 980 |
| 6/10 | 6/10 | 6/10 | 6/10 |
| 2150 | 2150 | 2170 | 2300 |
| 140 | 140 | 145 | 145 |
| 3300 | 3300 | 3300 | 3300 |
| 4355 | 4355 | 4355 | 4355 |
| 2145 | 2145 | 2165 | 2175 |
| 940 | 940 | 990 | 990 |
| 310 | 310 | 330 | 340 |
| 3555 | 3630 | 3805 | 3865 |
| 2485 | 2560 | 2735 | 2795 |
| 1150 / 1640 | 1150 / 1640 | 1275/1690 | 1290/1690 |
| 40x100x1070 | 40x100x1070 | 45x125x1070 | 45x125x1070 |
| 2A | 2A | 3A | 3A |
| 1000 | 1000 | 1000 | 1000 |
| 115 | 115 | 135 | 150 |
| 135 | 135 | 165 | 170 |
| 3855 | 3890 | 4075 | 4135 |
| 3655 | 3690 | 3875 | 3935 |
| 4055 | 4090 | 4275 | 4335 |
| 2200 | 2230 | 2380 | 2440 |
| 715 | 715 | 780 | 780 |
| 19,0/19,5 | 19,0/19,5 | 19,0/19,5 | 16,5/18,0 |
| 0,59 / 0,61 | 0,59 / 0,61 | 0,52 / 0,53 | 0,43 / 0,44 |
| 0,50 / 0,50 | 0,50 / 0,50 | 0,53 / 0,50 | 0,42 / 0,40 |
| 17100/16800 | 17100/16700 | 21800/21400 | 19900/19800 |
| -/- | -/- | -/- | -/- |
| 35/60 | 30/53 | 32/60 | 26/48 |
| -/- | -/- | -/- | -/- |
| -/- | -/- | -/- | -/- |
| Hydraulic | Hydraulic | Hydraulic | Hydraulic |
| GK21E | GK21E | GK25E | GK25E |
| 41.0 | 41.0 | 46.9 | 46.9 |
| 2700 | 2700 | 2700 | 2700 |
| 4 / 2065 | 4 / 2065 | 4 / 2488 | 4 / 2488 |
| 151 | 151 | 188 | 188 |
| 1800 | 1800 | 1600 | 1600 |
| Powershift 1/1 | Powershift 1/1 | Powershift 1/1 | Powershift 1/1 |
| 180 | 180 | 180 | 180 |
| 73 | 73 | 73 | 73 |
| 79 | 79 | 79 | 79 |
| Pin | Pin | Pin | Pin |

FD/FGE15-35(C)-E2

MAST SPECIFICATIONS & RATED CAPACITIES

| MAST TYPE | Mast Name | Max fork height (mm) | Overall mast height lowered (mm) | | | | Free lift (mm) | | Mast tilt forward/backward (degrees) | FGE15-E2 | FGE18-E2 | FGE20C-E2 |
|-----------|-----------|----------------------|----------------------------------|-------------------|------------------|-------------------|------------------|---|--------------------------------------|------------------|----------|-----------|
| | | | Lowered | Extended | | With STD backrest | Without Backrest | Load Capacity (kgs) @ 500mm load centre | | | | |
| | | | | With STD backrest | Without Backrest | | | With STD backrest | | Without Backrest | | |
| SIMPLEX | 2SP30 | 3000 | 1990 | 4055 | 3635 | 80 | 80 | 6-10 | 1500 | 1750 | 2000 | |
| | 2SP33 | 3300 | 2140 | 4355 | 3935 | 80 | 80 | 6-10 | 1500 | 1750 | 2000 | |
| | 2SP35 | 3500 | 2240 | 4555 | 4135 | 80 | 80 | 6-10 | 1500 | 1750 | 2000 | |
| | 2SP37 | 3700 | 2340 | 4755 | 4335 | 80 | 80 | 6-6 | 1500 | 1750 | 2000 | |
| | 2SP40 | 4000 | 2540 | 5055 | 4635 | 80 | 80 | 6-6 | 1500 | 1750 | 2000 | |
| | 2SP45 | 4500 | 2790 | 5555 | 5135 | 80 | 80 | 6-6 | 1425 | 1700 | 1950 | |
| | 2SP50 | 5000 | 3050 | 6055 | 5635 | 80 | 80 | 6-6 | 1375 | 1400 | 1400 | |
| | 2SP55 | 5500 | 3300 | 6555 | 6135 | 80 | 80 | 6-6 | 850 | 850 | | |
| | 2SP60 | 6000 | 3550 | 7055 | 6635 | 80 | 80 | 6-6 | 525 | 525 | | |
| DUPLEX | 2FP30 | 3000 | 1995 | 4055 | 3635 | 940 | 1360 | 6-10 | 1500 | 1750 | 2000 | |
| | 2FP33 | 3300 | 2140 | 4350 | 3930 | 1085 | 1505 | 6-10 | 1500 | 1750 | 2000 | |
| | 2FP35 | 3530 | 2260 | 4570 | 4150 | 1205 | 1625 | 6-10 | 1500 | 1750 | 2000 | |
| | 2FP40 | 4020 | 2585 | 5085 | 4665 | 1530 | 1950 | 6-6 | 1500 | 1750 | 2000 | |
| TRIPLEX | 3FP37 | 3700 | 1790 | 4755 | 4335 | 735 | 1155 | 6-6 | 1500 | 1750 | 2000 | |
| | 3FP40 | 4000 | 1890 | 5055 | 4635 | 835 | 1255 | 6-6 | 1475 | 1750 | 2000 | |
| | 3FP43 | 4300 | 1990 | 5355 | 4935 | 935 | 1355 | 6-6 | 1425 | 1700 | 1950 | |
| | 3FP47 | 4700 | 2140 | 5755 | 5335 | 1085 | 1505 | 6-6 | 1375 | 1625 | 1900 | |
| | 3FP50 | 5000 | 2240 | 6055 | 5635 | 1185 | 1605 | 6-6 | 1325 | 1325 | 1325 | |
| | 3FP55 | 5500 | 2430 | 6555 | 6135 | 1375 | 1795 | 6-6 | 850 | 850 | | |
| | 3FP60 | 6000 | 2610 | 7055 | 6635 | 1555 | 1975 | 6-6 | 525 | 525 | | |
| | 3FP65 | 6500 | 2850 | 7555 | 7135 | 1795 | 2215 | 6-6 | 350 | 350 | | |
| | 3FP70 | 7000 | 3050 | 8055 | 7635 | 1995 | 2415 | 6-6 | 175 | 175 | | |

The capacities are applicable for pneumatic shaped solid tyres (SE).

| MAST TYPE | Mast Name | Max fork height (mm) | Overall mast height lowered (mm) | | | | Free lift (mm) | | Mast tilt forward/backward (degrees) | FD/FGE20-E2 | FD/FGE25-E2 |
|-----------|-----------|----------------------|----------------------------------|-------------------|------------------|-------------------|------------------|---|--------------------------------------|------------------|-------------|
| | | | Lowered | Extended | | With STD backrest | Without Backrest | Load Capacity (kgs) @ 500mm load centre | | | |
| | | | | With STD backrest | Without Backrest | | | With STD backrest | | Without Backrest | |
| SIMPLEX | 2SP30 | 3000 | 1995 | 4055 | 3635 | 120 | 120 | 6°/10° | 2000 | 2500 | |
| | 2SP33 | 3300 | 2145 | 4355 | 3935 | 120 | 120 | 6°/10° | 2000 | 2500 | |
| | 2SP35 | 3500 | 2245 | 4555 | 4135 | 120 | 120 | 6°/10° | 2000 | 2500 | |
| | 2SP37 | 3700 | 2345 | 4755 | 4335 | 120 | 120 | 6°/6° | 2000 | 2500 | |
| | 2SP40 | 4000 | 2545 | 5055 | 4635 | 120 | 120 | 6°/6° | 2000 | 2500 | |
| | 2SP45 | 4500 | 2795 | 5555 | 5135 | 120 | 120 | 6°/6° | 1950 | 2450* | |
| | 2SP50 | 5000 | 3065 | 6055 | 5635 | 120 | 120 | 6°/6° | 1900* | 2350* | |
| | 2SP55 | 5500 | 3315 | 6555 | 6135 | 120 | 120 | 6°/6° | 1850* | 2250* | |
| | 2SP60 | 6000 | 3565 | 7055 | 6635 | 120 | 120 | 6°/6° | 1800* | 2150* | |
| DUPLEX | 2FP30 | 3000 | 1995 | 4055 | 3660 | 980 | 1375 | 6°/10° | 2000 | 2500 | |
| | 2FP33 | 3300 | 2145 | 4350 | 3960 | 1130 | 1525 | 6°/10° | 2000 | 2500 | |
| | 2FP35 | 3530 | 2265 | 4585 | 4190 | 1250 | 1645 | 6°/10° | 2000 | 2500 | |
| | 2FP40 | 4020 | 2590 | 5075 | 4680 | 1575 | 1970 | 6°/6° | 2000 | 2500 | |
| TRIPLEX | 3FP37 | 3700 | 1795 | 4755 | 4360 | 780 | 1180 | 6°/6° | 2000 | 2500 | |
| | 3FP40 | 4000 | 1895 | 5055 | 4660 | 880 | 1280 | 6°/6° | 2000 | 2500 | |
| | 3FP43 | 4300 | 1995 | 5355 | 4960 | 980 | 1380 | 6°/6° | 1950 | 2450 | |
| | 3FP47 | 4700 | 2145 | 5755 | 5360 | 1130 | 1530 | 6°/6° | 1900 | 2350* | |
| | 3FP50 | 5000 | 2245 | 6055 | 5660 | 1230 | 1630 | 6°/6° | 1850* | 2300* | |
| | 3FP55 | 5500 | 2415 | 6555 | 6160 | 1400 | 1800 | 6°/6° | 1800* | 2200* | |
| | 3FP60 | 6000 | 2585 | 7055 | 6660 | 1570 | 1970 | 6°/6° | 1750* | 2100* | |
| | 3FP65 | 6500 | 2795 | 7555 | 7160 | 1780 | 2180 | 6°/6° | 1650* | 1750* | |
| 3FP70 | 7000 | 3065 | 8055 | 7660 | 2050 | 2450 | 6°/6° | 1250* | 1250* | | |

The capacities are applicable for pneumatic shaped solid tyres (SE).

*Capacities shown require truck equipped with dual tyres. Consult Residual capacity charts for the maximum back tilt allowed, to obtain the capacities specified.

| MAST TYPE | Mast Name | Max fork height (mm) | Overall mast height lowered (mm) | | | Free lift (mm) | | Mast tilt forward/backward/ (degrees) | FD/FGE30-E2 |
|-----------|-----------|----------------------|----------------------------------|-------------------|------------------|-------------------|------------------|---------------------------------------|---|
| | | | Lowered | Extended | | With STD backrest | Without Backrest | | Load Capacity (kgs) @ 500mm load centre |
| | | | | With STD backrest | Without Backrest | | | | |
| SIMPLEX | 2SP30 | 3000 | 2015 | 4055 | 3690 | 140 | 140 | 6 - 10 | 3000 |
| | 2SP33 | 3300 | 2165 | 4355 | 3990 | 140 | 140 | 6 - 10 | 3000 |
| | 2SP35 | 3500 | 2265 | 4555 | 4190 | 140 | 140 | 6 - 10 | 3000 |
| | 2SP37 | 3700 | 2365 | 4755 | 4390 | 140 | 140 | 6 - 6 | 3000 |
| | 2SP40 | 4000 | 2565 | 5055 | 4690 | 140 | 140 | 6 - 6 | 3000 |
| | 2SP45 | 4500 | 2815 | 5555 | 5190 | 140 | 140 | 6 - 6 | 2950 |
| | 2SP50 | 5000 | 3115 | 6055 | 5690 | 140 | 140 | 6 - 6 | 2850 |
| | 2SP55 | 5500 | 3365 | 6555 | 6190 | 140 | 140 | 6 - 6 | 2750 |
| | 2SP60 | 6000 | 3615 | 7055 | 6690 | 140 | 140 | 6 - 6 | 2400* |
| DUPLEX | 2FP30 | 3000 | 2045 | 4055 | 3705 | 1035 | 1385 | 6 - 10 | 3000 |
| | 2FP33 | 3250 | 2165 | 4305 | 3955 | 1155 | 1505 | 6 - 10 | 3000 |
| | 2FP35 | 3490 | 2285 | 4545 | 4195 | 1275 | 1625 | 6 - 10 | 3000 |
| | 2FP40 | 4010 | 2610 | 5065 | 4715 | 1600 | 1950 | 6 - 6 | 3000 |
| TRIPLEX | 3FP37 | 3700 | 1815 | 4755 | 4395 | 760 | 1165 | 6 - 6 | 3000 |
| | 3FP40 | 4000 | 1915 | 5055 | 4695 | 860 | 1265 | 6 - 6 | 3000 |
| | 3FP43 | 4300 | 2015 | 5355 | 4995 | 960 | 1365 | 6 - 6 | 3000 |
| | 3FP47 | 4700 | 2165 | 5755 | 5395 | 1110 | 1515 | 6 - 6 | 2900 |
| | 3FP50 | 5000 | 2265 | 6055 | 5695 | 1210 | 1615 | 6 - 6 | 2800 |
| | 3FP55 | 5500 | 2435 | 6555 | 6195 | 1380 | 1785 | 6 - 6 | 2750 |
| | 3FP60 | 6000 | 2605 | 7055 | 6695 | 1550 | 1955 | 6 - 6 | 2400* |
| | 3FP65 | 6500 | 2815 | 7555 | 7195 | 1760 | 2165 | 6 - 6 | 1750* |
| 3FP70 | 7000 | 3115 | 8055 | 7695 | 2060 | 2465 | 6 - 6 | 1250* | |

The capacities are applicable for pneumatic shaped solid tyres (SE).

*Capacities shown require truck equipped with dual tyres. Consult Residual capacity charts for the maximum back tilt allowed, to obtain the capacities specified.

| MAST TYPE | Mast Name | Max fork height (mm) | Overall mast height lowered (mm) | | | Free lift (mm) | | Mast tilt forward/backward/ (degrees) | FD/FGE35-E2 |
|-----------|-----------|----------------------|----------------------------------|-------------------|------------------|-------------------|------------------|---------------------------------------|---|
| | | | Lowered | Extended | | With STD backrest | Without Backrest | | Load Capacity (kgs) @ 500mm load centre |
| | | | | With STD backrest | Without Backrest | | | | |
| SIMPLEX | 2SP30 | 3000 | 2130 | 4055 | 3755 | 140 | 140 | 6 - 10 | 3500 |
| | 2SP33 | 3300 | 2280 | 4355 | 4055 | 140 | 140 | 6 - 10 | 3500 |
| | 2SP35 | 3500 | 2380 | 4555 | 4255 | 140 | 140 | 6 - 10 | 3500 |
| | 2SP37 | 3700 | 2480 | 4755 | 4455 | 140 | 140 | 6 - 6 | 3500 |
| | 2SP40 | 4000 | 2680 | 5055 | 4755 | 140 | 140 | 6 - 6 | 3500 |
| | 2SP45 | 4500 | 2930 | 5555 | 5255 | 140 | 140 | 6 - 6 | 3500 |
| | 2SP50 | 5000 | 3230 | 6055 | 5755 | 140 | 140 | 6 - 6 | 3400* |
| | 2SP55 | 5500 | 3480 | 6555 | 6255 | 140 | 140 | 6 - 6 | 3200* |
| | 2SP60 | 6000 | 3730 | 7055 | 6755 | 140 | 140 | 6 - 6 | 2400* |
| DUPLEX | 2FP30 | 3010 | 2180 | 4065 | 3825 | 1170 | 1410 | 6 - 10 | 3500 |
| | 2FP33 | 3300 | 2300 | 4355 | 4115 | 1290 | 1530 | 6 - 10 | 3500 |
| | 2FP35 | 3500 | 2445 | 4555 | 4315 | 1435 | 1675 | 6 - 10 | 3500 |
| | 2FP40 | 4000 | 2765 | 5055 | 4815 | 1755 | 1995 | 6 - 6 | 3500 |
| TRIPLEX | 3FP37 | 3700 | 1930 | 4755 | 4500 | 920 | 1170 | 6 - 6 | 3500 |
| | 3FP40 | 4000 | 2030 | 5055 | 4800 | 1020 | 1270 | 6 - 6 | 3500 |
| | 3FP43 | 4300 | 2130 | 5355 | 5100 | 1120 | 1370 | 6 - 6 | 3500 |
| | 3FP47 | 4700 | 2280 | 5755 | 5500 | 1270 | 1520 | 6 - 6 | 3450 |
| | 3FP50 | 5000 | 2380 | 6055 | 5800 | 1370 | 1620 | 6 - 6 | 3350 |
| | 3FP55 | 5500 | 2550 | 6555 | 6300 | 1540 | 1790 | 6 - 6 | 3200* |
| | 3FP60 | 6000 | 2720 | 7055 | 6800 | 1710 | 1960 | 6 - 6 | 2400* |
| | 3FP65 | 6500 | 2930 | 7555 | 7300 | 1920 | 2170 | 6 - 6 | 1750* |
| 3FP70 | 7000 | 3230 | 8055 | 7800 | 2220 | 2470 | 6 - 6 | 1250* | |

The capacities are applicable for pneumatic shaped solid tyres (SE).

*Capacities shown require truck equipped with dual tyres. Consult Residual capacity charts for the maximum back tilt allowed, to obtain the capacities specified.

FD/FGE15-35(C)-E2

STANDARD AND OPTIONS LIST

| | DIESEL | LPG | |
|---|------------|--------------|-------------|
| | FD20-35-E2 | FGE15-20C-E2 | FGE20-35-E2 |
| GENERAL | | | |
| Fully floating powertrain | ● | ● | ● |
| 1-Speed Powershift transmission for all models | ● | ● | ● |
| Single cast drive-axle | ● | ● | ● |
| Drum Brake System | ● | ● | ● |
| Double action parking brake with audible alarm | ● | ● | ● |
| Single solid pneumatic drive and steer tires | ● | ● | ● |
| Starter protection (anti restarter) | ● | ● | ● |
| Presence Detection System | ● | ● | ● |
| Neutral safety (Start inhibition in F/R) | ● | ● | ● |
| Corrugated wave fin type aluminium radiator | ● | ● | ● |
| Low Exhaust | ● | ● | ● |
| Elevated air intake | ● | ● | ● |
| Mechanical hydraulic levers | ● | ● | ● |
| Engine cover opening latch with engine shut-off sensor | ● | ● | ● |
| Engine cover insulator | ● | ● | ● |
| Engine under cover | ● | ● | ● |
| Battery quick-disconnect terminal | ● | ● | ● |
| Rubber Floor Mat | ● | ● | ● |
| Anti-skid step (on both sides) | ● | ● | ● |
| Full hydrostatic steering | ● | ● | ● |
| Tilt steering column with memory position | ● | ● | ● |
| Load weight indicator (for simplex & triplex masts) | ● | ● | ● |
| Grammer MSG65 Full suspension vinyl seat with orange belt and seat switch | ● | ● | ● |
| Steering wheel knob | ● | ● | ● |
| Audible back-up alarm | ● | ● | ● |
| Backup handle with horn | ● | ● | ● |
| LED front work lights, front indicator and rear combi lamp | ● | ● | ● |
| Cup holder | ● | ● | ● |
| Drawbar pin | ● | ● | ● |
| Deluxe Cabin | ● | — | ● |
| Dust proof kit | ● | ● | ● |
| Line filter for torque converter | ● | ● | ● |
| Rear view mirrors | ● | ● | ● |
| LPG swing down bracket, no tank | — | ● | ● |
| Tilt cylinder boot kit | ● | ● | ● |
| Universal Joint cover for powertrain | ● | ● | ● |

| | DIESEL | LPG | |
|------------------------------------|------------|--------------|-------------|
| | FD20-35-E2 | FGE15-20C-E2 | FGE20-35-E2 |
| CARRIAGES | | | |
| Side shift | ● | ● | ● |
| Integral side shift | ● | ● | ● |
| HYDRAULIC CONTROL | | | |
| 3-way control | ● | ● | ● |
| 4-way control | ● | ● | ● |
| PIPING & HOSING | | | |
| 3-way piping | ● | ● | ● |
| 4-way piping | ● | ● | ● |
| AIR INTAKE & EXHAUST | | | |
| Single element air cleaner | ● | — | — |
| Double element cyclone air cleaner | ● | ● | ● |
| Elevated exhaust | ● | ● | ● |
| COOLING SYSTEM | | | |
| Corrugated square radiator | ● | ● | ● |
| Anti-clog net for radiator | ● | ● | ● |
| High speed fan | ● | ● | ● |
| SEATS | | | |
| Grammer MSG65 Vinyl seat | ● | ● | ● |
| Grammer MSG65 Cloth seat | ● | ● | ● |
| Integrated Presence System | ● | ● | ● |
| ELECTRICAL | | | |
| Backup handle with horn button | ● | ● | ● |
| Electric diesel control | ● | — | — |
| Speed control system | — | ● | ● |
| LED rear work light | ● | ● | ● |
| Rotating beacon (orange) | ● | ● | ● |
| Rear Blue lamp | ● | ● | ● |
| Strobe light (orange) | ● | ● | ● |
| Large capacity battery | — | ● | ● |

KEY ● Standard ● Optional — Not available



TCM
Always Evolving

info@tcm.eu | tcm.eu

© 2021 MLE B.V. (registration no. 33274459). All rights reserved.

MLE B.V. reserves the right to make any changes without notice concerning colours, equipment or specifications detailed in this brochure, or to discontinue individual models. The colours of vehicles delivered may differ slightly from those in this brochure. The specifications vary for different countries depending on local market conditions. Please consult your local dealer to ensure that the vehicle delivered accords with your expectations. All values are determined based on the standard condition and may vary, due to motor and system tolerances, condition of the truck and operational conditions. Some equipment shown on photos maybe optional. CEST2145