

PRELIMINARY

TECHNICAL SPECIFICATIONS

# SPW/SPR10-16(I)(S)-N3



# SPW10-16-N3

## STANDARD SPECIFICATIONS PRELIMINARY

CHARACTERISTICS				WITHOUT INITIAL LIFT - NARROW STRADDLE			
				SPW10-N3	SPW12-N3	SPW14-N3	SPW16-N3
1.1	Manufacturer			TCM	TCM	TCM	TCM
1.2	Manufacturer's model designation			SPW10-N3	SPW12-N3	SPW14-N3	SPW16-N3
1.3	Power source			Battery	Battery	Battery	Battery
1.4	Operator type			Pedestrian	Pedestrian	Pedestrian	Pedestrian
1.5	Load capacity	Q	(kg)	1000	1200	1400	1600
1.6	Load center distance	c	(mm)	600	600	600	600
1.8	Load wheel axle to fork face (forks lowered)	x	(mm)	700	750	750	750
1.9	Wheelbase	y	(mm)	1215	1330	1330	1330
<b>WEIGHT</b>							
2.1b	Truck weight without load, with maximum battery weight		kg	730	1020	1020	1020
2.2	Axle loadings with nominal load & maximum battery weight, drive / load side		kg	612 / 1128	810 / 1410	845 / 1580	870 / 1755
2.3	Axle loadings without load & with maximum battery weight, drive / load side		kg	534 / 196	730 / 295	730 / 295	730 / 295
<b>WHEELS, DRIVE TRAIN</b>							
3.1	Tyres			Vulkollan	Vulkollan	Vulkollan	Vulkollan
3.2	Tyre dimensions, drive side		(mm)	230 x 70	230 x 70	230 x 70	230 x 70
3.3	Tyre dimensions, load side	ø	(mm)	85 x 90	85 x 90	85 x 75	85 x 75
3.4	Castor wheel dimensions (diameter x width)		(mm)	125 x 60	125 x 60	125 x 60	125 x 60
3.5	Number of wheels, load / drive side (x = driven)			1 + 1x / 2	1 + 1x / 2	1 + 1x / 4	1 + 1x / 4
3.6	Track width (center of tyres), drive side	b10	(mm)	515	515	515	515
3.7	Track width (center of tyres), load side	b11	(mm)	385	385	385	385
<b>DIMENSIONS</b>							
4.2a	Height with mast lowered	h1	(mm)	see tables	see tables	see tables	see tables
4.3	Free lift	h2	(mm)	see tables	see tables	see tables	see tables
4.4	Lift height	h3	(mm)	see tables	see tables	see tables	see tables
4.5	Height with mast extended	h4	(mm)	see tables	see tables	see tables	see tables
4.6	Initial lift	h5	(mm)	-	-	-	-
4.9	Height of tiller arm/steering console (min / max)	h14	(mm)	865 / 1420	865 / 1420	865 / 1420	865 / 1420
4.15	Fork height, fully lowered	h13	(mm)	90	90	90	90
4.19	Overall length	l1	(mm)	1835	1900	1900	1900
4.2	Length to fork face	l2	(mm)	685	750	750	750
4.21	Overall width	b1 / b2	(mm)	800	800	800	800
4.22	Fork dimensions (thickness, width, length)	s / e / l	(mm)	56 / 186 / 1150	56 / 186 / 1150	56 / 186 / 1150	56 / 186 / 1150
4.24	Fork carriage width	b3	(mm)	750	750	750	750
4.25	Outside width over forks (minimum / maximum)	b5	(mm)	570	570	570	570
4.26	Inner width of support legs	b4	(mm)	-	-	-	-
4.32	Ground clearance at center of wheelbase, (forks lowered)	m2	(mm)	20	20	20	20
4.33c	Working aisle width (Ast) with 1000 x 1200 mm pallets, load crosswise, platform up/down	Ast	(mm)	2300	2445	2445	2445
4.34c	Working aisle width (Ast3) with 800 x 1200 mm pallets, load lengthwise, platform up / down	Ast	(mm)	2300	2374	2374	2374
4.35	Turning radius	Wa	(mm)	1458	1572	1572	1572
<b>PERFORMANCE</b>							
5.1	Travel speed, with / without load		km / h	6.0 / 6.0	6.0 / 6.0	6.0 / 6.0	6.0 / 6.0
5.2	Lifting speed, with / without load		m / s	0.15 / 0.30	0.16 / 0.33	0.14 / 0.33	0.15 / 0.32
5.3	Lowering speed, with / without load		m / s	0.29 / 0.32	0.46 / 0.35	0.45 / 0.35	0.48 / 0.34
5.8	Maximum gradeability, with / without load		%	8 / 15	8 / 15	8 / 15	8 / 15
5.10	Service brakes (mechanical / hydraulic / electric / pneumatic)			Electric	Electric	Electric	Electric
<b>ELECTRIC MOTORS</b>							
6.1	Drive motor capacity (60 min. short duty)		kW	1	1	1	1
6.2	Lift motor output at 15% duty factor		kW	2.2	2.2	2.2	2.2
6.4	Battery voltage/capacity at 5-hour discharge		V / Ah	24 / 150	24 / 250	24 / 250	24 / 250 - 375
6.5	Battery weight		kg	150	210	210	210
6.6a	Energy consumption according to EN16796		kWh/h	0.46	0.76	0.77	0.77
<b>MISCELLANEOUS</b>							
8.1	Type of drive control			Stepless	Stepless	Stepless	Stepless
10.7	Level of noise at the ear level of the driver according to EN 12 053:2001 and EN ISO 4871 in work LpAZ		dB (A)	65	64		
10.7.2	Whole-body vibration (EN 13 059:2002)			-	-	-	-
10.7.3	Hand-arm vibration (EN 13 059:2002)			< 2.5	< 2.5	< 2.5	< 2.5

# DIMENSIONS

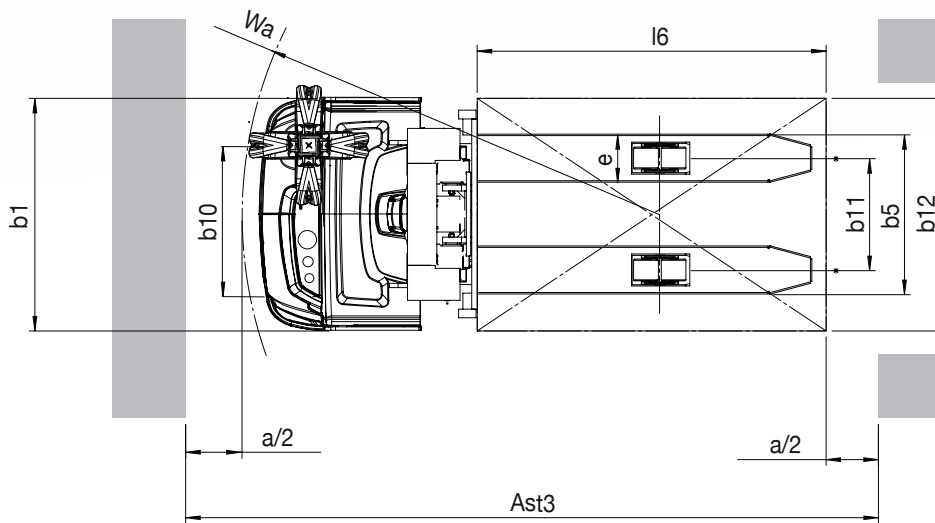
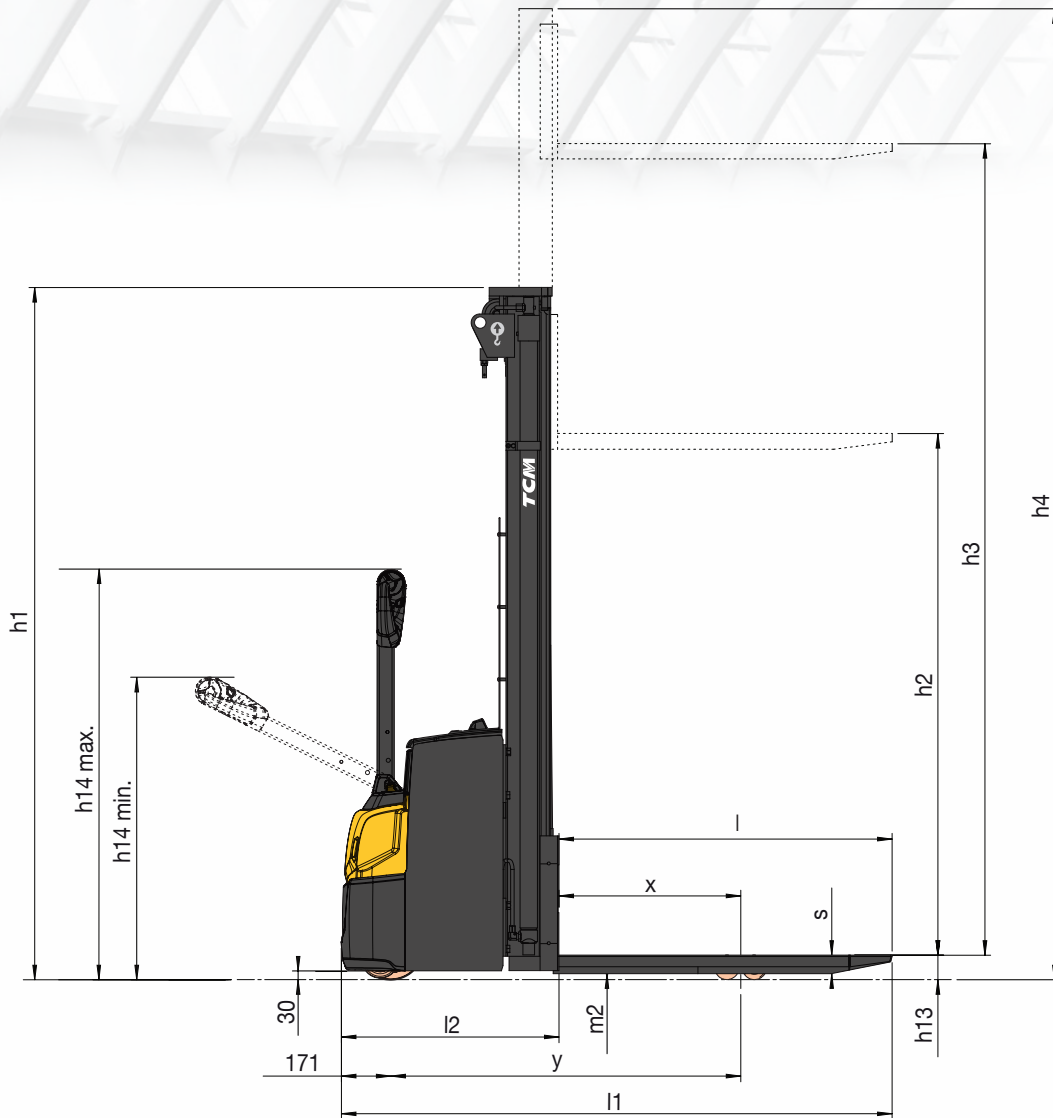

# SPW12-16I-N3

## STANDARD SPECIFICATIONS PRELIMINARY

CHARACTERISTICS				WITH INITIAL LIFT - NARROW STRADDLE		
				SPW12I-N3	SPW14I-N3	SPW16I-N3
1.1	Manufacturer			TCM	TCM	TCM
1.2	Manufacturer's model designation			SPW12I-N3	SPW14I-N3	SPW16I-N3
1.3	Power source			Battery	Battery	Battery
1.4	Operator type			Pedestrian	Pedestrian	Pedestrian
1.5	Load capacity	Q	(kg)	1200	1400	1600
1.6	Load center distance	c	(mm)	600	600	600
1.8	Load wheel axle to fork face (forks lowered)	x	(mm)	925	925	925
1.9	Wheelbase	y	(mm)	1610	1610	1610
<b>WEIGHT</b>						
2.1b	Truck weight without load, with maximum battery weight		kg	1095	1095	1095
2.2	Axle loadings with nominal load & maximum battery weight, drive / load side		kg	1060 / 1230	1105 / 1390	1145 / 1545
2.3	Axle loadings without load & with maximum battery weight, drive / load side		kg	780 / 315	780 / 312	780 / 312
<b>WHEELS, DRIVE TRAIN</b>						
3.1	Tyres			Vulkollan	Vulkollan	Vulkollan
3.2	Tyre dimensions, drive side		(mm)	230 x 70	230 x 70	230 x 70
3.3	Tyre dimensions, load side	ø	(mm)	85 x 90	85 x 75	85 x 75
3.4	Castor wheel dimensions (diameter x width)		(mm)	125 x 60	125 x 60	125 x 60
3.5	Number of wheels, load / drive side (x = driven)			1 + 1x / 2	1 + 1x / 4	1 + 1x / 4
3.6	Track width (center of tyres), drive side	b10	(mm)	515	515	515
3.7	Track width (center of tyres), load side	b11	(mm)	385	385	385
<b>DIMENSIONS</b>						
4.2a	Height with mast lowered	h1	(mm)	see tables	see tables	see tables
4.3	Free lift	h2	(mm)	see tables	see tables	see tables
4.4	Lift height	h3	(mm)	see tables	see tables	see tables
4.5	Height with mast extended	h4	(mm)	see tables	see tables	see tables
4.6	Initial lift	h5	(mm)	200	200	200
4.9	Height of tiller arm/steering console (min / max)	h14	(mm)	865 / 1420	865 / 1420	865 / 1420
4.15	Fork height, fully lowered	h13	(mm)	90	90	90
4.19	Overall length	l1	(mm)	2010	2010	2010
4.2	Length to fork face	l2	(mm)	855	855	855
4.21	Overall width	b1 / b2	(mm)	800	800	800
4.22	Fork dimensions (thickness, width, length)	s / e / l	(mm)	56 / 186 / 1150	56 / 186 / 1150	56 / 186 / 1150
4.24	Fork carriage width	b3	mm	750	750	750
4.25	Outside width over forks (minimum / maximum)	b5	(mm)	570	570	570
4.26	Inner width of support legs	b4	(mm)	-	-	-
4.32	Ground clearance at center of wheelbase, (forks lowered)	m2	(mm)	20	20	20
4.33c	Working aisle width (Ast) with 1000 x 1200 mm pallets, load crosswise, platform up/down	Ast	(mm)	2619	2619	2619
4.34c	Working aisle width (Ast3) with 800 x 1200 mm pallets, load lengthwise, platform up / down	Ast	(mm)	2533	2533	2533
4.35	Turning radius	Wa	(mm)	1848	1848	1848
<b>PERFORMANCE</b>						
5.1	Travel speed, with / without load		km / h	6.0 / 6.0	6.0 / 6.0	6.0 / 6.0
5.2	Lifting speed, with / without load		m / s	0.16 / 0.33	0.14 / 0.33	0.15 / 0.32
5.3	Lowering speed, with / without load		m / s	0.46 / 0.35	0.45 / 0.35	0.48 / 0.34
5.8	Maximum gradeability, with / without load		%	8 / 15	8 / 15	8 / 15
5.10	Service brakes (mechanical / hydraulic / electric / pneumatic)			Electric	Electric	Electric
<b>ELECTRIC MOTORS</b>						
6.1	Drive motor capacity (60 min. short duty)		kW	1	1	1
6.2	Lift motor output at 15% duty factor		kW	2.2	2.2	2.2
6.4	Battery voltage/capacity at 5-hour discharge		V / Ah	24 / 250	24 / 250	24 / 250 - 375
6.5	Battery weight		kg	210	210	210
6.6a	Energy consumption according to EN16796		kWh/h	0.76	0.77	0.77
<b>MISCELLANEOUS</b>						
8.1	Type of drive control			Stepless	Stepless	Stepless
10.7	Level of noise at the ear level of the driver according to EN 12 053:2001 and EN ISO 4871 in work LpAZ		dB (A)	64		
10.7.2	Whole-body vibration (EN 13 059:2002)			-	-	-
10.7.3	Hand-arm vibration (EN 13 059:2002)			< 2.5	< 2.5	< 2.5

# DIMENSIONS

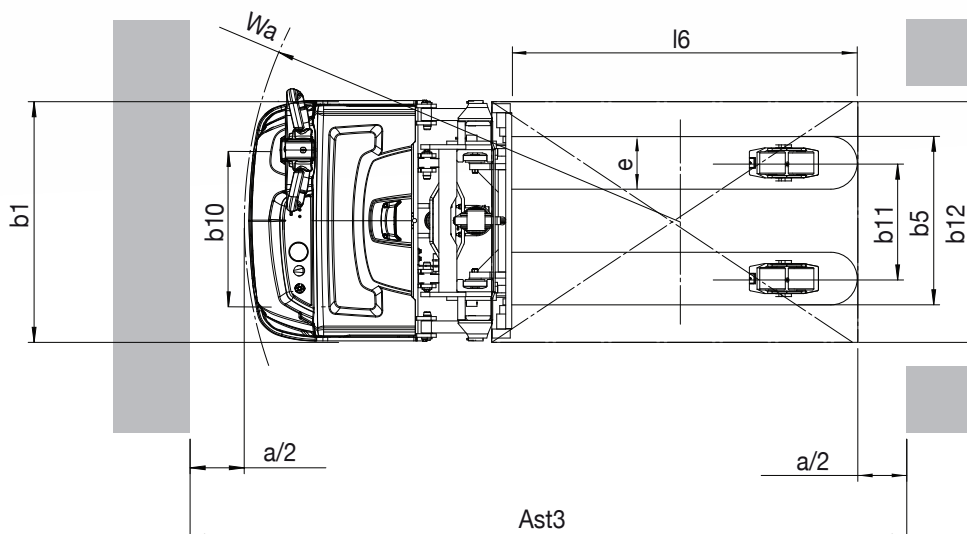
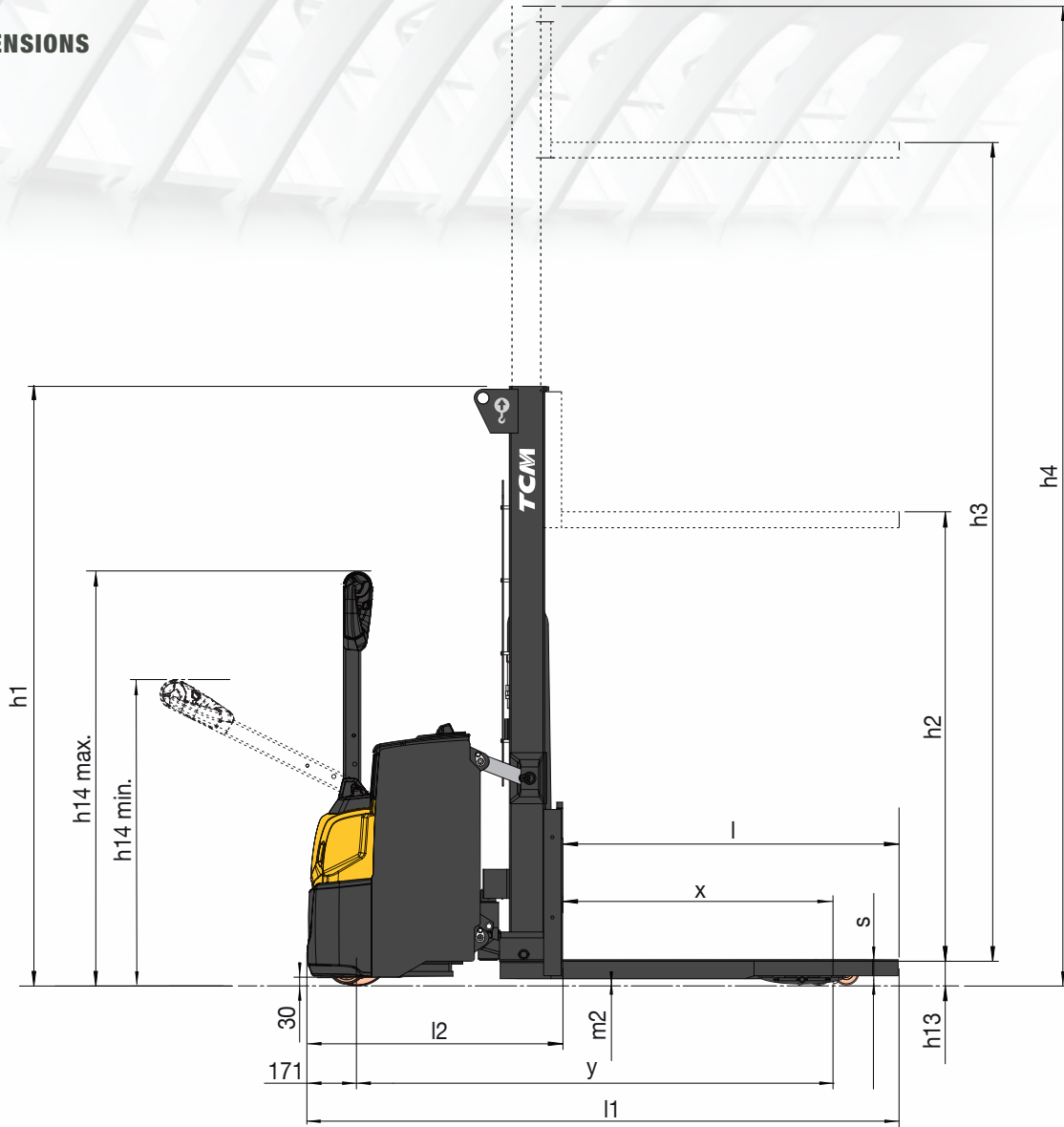

# SPW16S-N3

## STANDARD SPECIFICATIONS PRELIMINARY

CHARACTERISTICS				WITHOUT INITIAL LIFT WIDE STRADDLE
1.1	Manufacturer			TCM
1.2	Manufacturer's model designation			SPW16S-N3
1.3	Power source			Battery
1.4	Operator type			Pedestrian
1.5	Load capacity	Q	(kg)	1600
1.6	Load center distance	c	(mm)	600
1.8	Load wheel axle to fork face (forks lowered)	x	(mm)	750
1.9	Wheelbase	y	(mm)	1395
<b>WEIGHT</b>				
2.1b	Truck weight without load, with maximum battery weight		kg	1288
2.2	Axle loadings with nominal load & maximum battery weight, drive / load side		kg	1045 / 1870
2.3	Axle loadings without load & with maximum battery weight, drive / load side		kg	892 / 396
<b>WHEELS, DRIVE TRAIN</b>				
3.1	Tyres			Vulkollan
3.2	Tyre dimensions, drive side		(mm)	230 x 70
3.3	Tyre dimensions, load side		(mm)	85 x 75
3.4	Castor wheel dimensions (diameter x width)		(mm)	125 x 60
3.5	Number of wheels, load / drive side (x = driven)			1 + 1x / 4
3.6	Track width (center of tyres), drive side	b10	(mm)	515
3.7	Track width (center of tyres), load side	b11	(mm)	1025-1425
<b>DIMENSIONS</b>				
4.2a	Height with mast lowered	h1	(mm)	see tables
4.3	Free lift	h2	(mm)	see tables
4.4	Lift height	h3	(mm)	see tables
4.5	Height with mast extended	h4	(mm)	see tables
4.6	Initial lift	h5	(mm)	-
4.9	Height of tiller arm/steering console (min / max)	h14	(mm)	865 / 1420
4.15	Fork height, fully lowered	h13	(mm)	85
4.19	Overall length	l1	(mm)	1965
4.2	Length to fork face	l2	(mm)	815
4.21	Overall width	b1 / b2	(mm)	800 / 1140 - 1575
4.22	Fork dimensions (thickness, width, length)	s / e / l	(mm)	40 / 100 / 1150
4.24	Fork carriage width	b3	mm	980
4.25	Outside width over forks (minimum / maximum)	b5	(mm)	260 - 900
4.26	Inner width of support legs	b4	(mm)	900 - 1300
4.32	Ground clearance at center of wheelbase, (forks lowered)	m2	(mm)	20
4.33c	Working aisle width (Ast) with 1000 x 1200 mm pallets, load crosswise, platform up/down	Ast	(mm)	2580
4.34c	Working aisle width (Ast3) with 800 x 1200 mm pallets, load lengthwise, platform up / down	Ast	(mm)	2580
4.35	Turning radius	Wa	(mm)	1637
<b>PERFORMANCE</b>				
5.1	Travel speed, with / without load		km / h	6.0 / 6.0
5.2	Lifting speed, with / without load		m / s	0.15 / 0.32
5.3	Lowering speed, with / without load		m / s	0.43 / 0.34
5.8	Maximum gradeability, with / without load		%	8 / 15
5.10	Service brakes (mechanical / hydraulic / electric / pneumatic)			Electric
<b>ELECTRIC MOTORS</b>				
6.1	Drive motor capacity (60 min. short duty)		kW	1
6.2	Lift motor output at 15% duty factor		kW	3.2
6.4	Battery voltage/capacity at 5-hour discharge		V / Ah	24 / 250 - 375
6.5	Battery weight		kg	210
6.6a	Energy consumption according to EN16796		kWh/ h	0.77
<b>MISCELLANEOUS</b>				
8.1	Type of drive control			Stepless
10.7	Level of noise at the ear level of the driver according to EN 12 053:2001 and EN ISO 4871 in work LpAZ		dB (A)	
10.7.2	Whole-body vibration (EN 13 059:2002)			-
10.7.3	Hand-arm vibration (EN 13 059:2002)			< 2.5

## DIMENSIONS

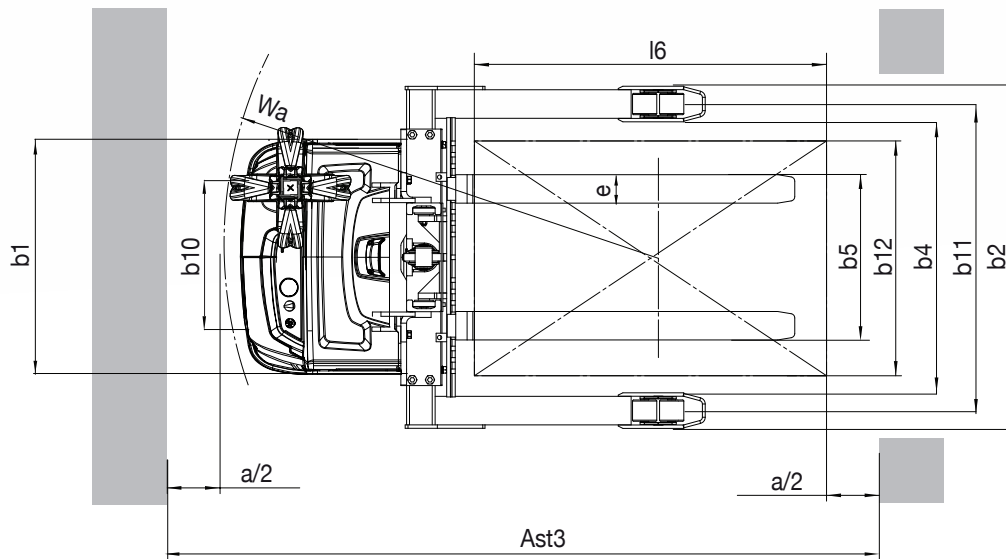
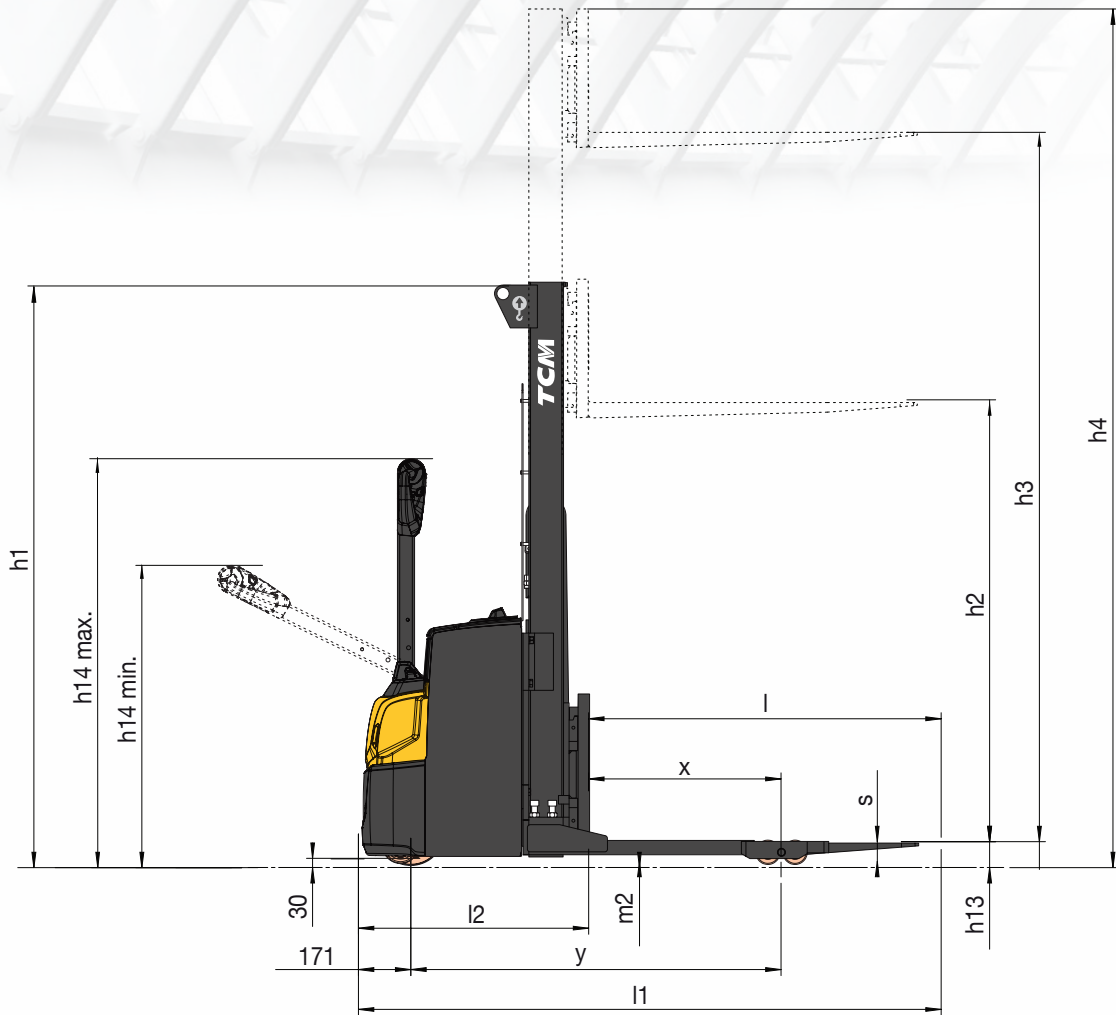

# SPR10-16-N3

## STANDARD SPECIFICATIONS PRELIMINARY

CHARACTERISTICS				FOLDABLE PLATFORM WITHOUT INITIAL LIFT - NARROW STRADDLE			
				SPR10-N3	SPR12-N3	SPR14-N3	SPR16-N3
1.1	Manufacturer			TCM	TCM	TCM	TCM
1.2	Manufacturer's model designation			SPR10-N3	SPR12-N3	SPR14-N3	SPR16-N3
1.3	Power source			Battery	Battery	Battery	Battery
1.4	Operator type			Pedestrian / Stand-on	Pedestrian / Stand-on	Pedestrian / Stand-on	Pedestrian / Stand-on
1.5	Load capacity	Q	(kg)	1000	1200	1400	1600
1.6	Load center distance	c	(mm)	600	600	600	600
1.8	Load wheel axle to fork face (forks lowered)	x	(mm)	700	750	750	750
1.9	Wheelbase	y	(mm)	1215	1330	1330	1330
<b>WEIGHT</b>							
2.1b	Truck weight without load, with maximum battery weight		kg	860	1100	1100	1100
2.2	Axle loadings with nominal load & maximum battery weight, drive / load side		kg	715 / 1155	840 / 1400	860 / 1580	990 / 1795
2.3	Axle loadings without load & with maximum battery weight, drive / load side		kg	640 / 220	860 / 320	740 / 295	860 / 320
<b>WHEELS, DRIVE TRAIN</b>							
3.1	Tyres			Vulkollan	Vulkollan	Vulkollan	Vulkollan
3.2	Tyre dimensions, drive side		(mm)	230 x 70	230 x 70	230 x 70	230 x 70
3.3	Tyre dimensions, load side	ø	(mm)	85 x 90	85 x 90	85 x 75	85 x 75
3.4	Castor wheel dimensions (diameter x width)		(mm)	125 x 60	125 x 60	125 x 60	125 x 60
3.5	Number of wheels, load / drive side (x = driven)			1 + 1x / 2	1 + 1x / 2	1 + 1x / 4	1 + 1x / 4
3.6	Track width (center of tyres), drive side	b10	(mm)	515	515	515	515
3.7	Track width (center of tyres), load side	b11	(mm)	385	385	385	385
<b>DIMENSIONS</b>							
4.2b	Height with mast lowered	h1	(mm)	see tables	see tables	see tables	see tables
4.3	Free lift	h2	(mm)	see tables	see tables	see tables	see tables
4.4	Lift height	h3	(mm)	see tables	see tables	see tables	see tables
4.5	Height with mast extended	h4	(mm)	see tables	see tables	see tables	see tables
4.8	Seat- or stand height	h7	(mm)	175	175	175	175
4.9	Height of tiller arm/steering console (min / max)	h14	(mm)	1155 / 1550	1155 / 1550	1155 / 1550	1155 / 1550
4.15	Fork height, fully lowered	h13	(mm)	90	90	90	90
4.19	Overall length	l1	(mm)	1955 / 2435	2020 / 2500	2020 / 2500	2020 / 2500
4.2	Length to fork face	l2	(mm)	805 / 1285	870 / 1350	870 / 1350	870 / 1350
4.21	Overall width	b1 / b2	(mm)	800	800	800	800
4.22	Fork dimensions (thickness, width, length)	s / e / l	(mm)	56 / 186 / 1150	56 / 186 / 1150	56 / 186 / 1150	56 / 186 / 1150
4.24	Fork carriage width	b3	(mm)	750	750	750	750
4.25	Outside width over forks (minimum / maximum)	b5	(mm)	570	570	570	570
4.32	Ground clearance at center of wheelbase, (forks lowered)	m2	(mm)	20	20	20	20
4.33c	Working aisle width (Ast) with 1000 x 1200 mm pallets, load crosswise, platform up/down	Ast	(mm)	2420 / 2900	2550 / 3050	2550 / 3050	2550 / 3050
4.34c	Working aisle width (Ast3) with 800 x 1200 mm pallets, load lengthwise, platform up / down	Ast	(mm)	2350 / 2830	2660 / 2980	2660 / 2980	2660 / 2980
4.35	Turning radius	Wa	(mm)	1578 / 2058	1692 / 2172	1692 / 2172	1684 / 2170
<b>PERFORMANCE</b>							
5.1	Travel speed, with / without load		km / h	6.0 / 6.0	6.0 / 6.0	6.0 / 6.0	6.0 / 6.0
5.2	Lifting speed, with / without load		m / s	0.15 / 0.30	0.16 / 0.33	0.14 / 0.33	0.15 / 0.32
5.3	Lowering speed, with / without load		m / s	0.29 / 0.32	0.46 / 0.35	0.45 / 0.35	0.43 / 0.34
5.8	Maximum gradeability, with / without load		%	8 / 15	8 / 15	8 / 15	8 / 15
5.10	Service brakes (mechanical / hydraulic / electric / pneumatic)			Electric	Electric	Electric	Electric
<b>ELECTRIC MOTORS</b>							
6.1	Drive motor capacity (60 min. short duty)		kW	1	1	1	1
6.2	Lift motor output at 15% duty factor		kW	2.2	2.2	2.2	3.2
6.4	Battery voltage/capacity at 5-hour discharge		V / Ah	24 / 150 - 250	24 / 150 - 250	24 / 250	24 / 250 - 375
6.5	Battery weight		kg	150	210	210	210
6.6a	Energy consumption according to EN16796		kWh/h	0.75	0.77	0.78	0.78
<b>MISCELLANEOUS</b>							
8.1	Type of drive control			Stepless	Stepless	Stepless	Stepless
10.7.1	Level of noise at the ear level of the driver according to EN 12 053:2001 and EN ISO 4871, drive/lift/idle LpAZ		dB (A)				
10.7.2	Whole-body vibration (EN 13 059:2002)			0.8	0.8	0.8	0.8
10.7.3	Hand-arm vibration (EN 13 059:2002)			< 2.5	< 2.5	< 2.5	< 2.5



## DIMENSIONS

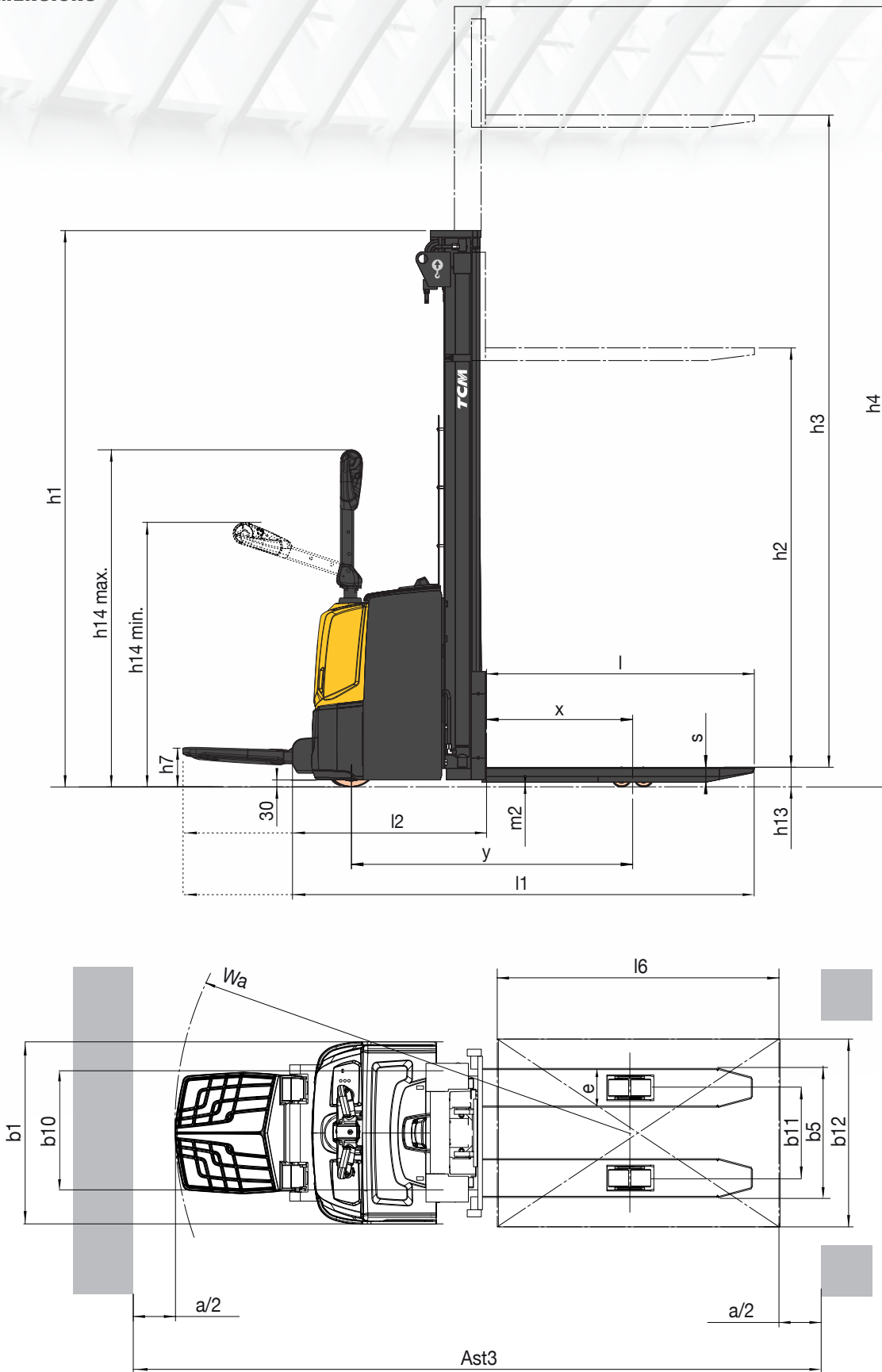

# SPR12-16I-N3

## STANDARD SPECIFICATIONS PRELIMINARY

CHARACTERISTICS				FOLDABLE PLATFORM WITH INITIAL LIFT - NARROW STRADDLE		
				SPR12I-N3	SPR14I-N3	SPR16I-N3
1.1	Manufacturer			TCM	TCM	TCM
1.2	Manufacturer's model designation			SPR12I-N3	SPR14I-N3	SPR16I-N3
1.3	Power source			Battery	Battery	Battery
1.4	Operator type			Pedestrian / Stand-on	Pedestrian / Stand-on	Pedestrian / Stand-on
1.5	Load capacity	Q	(kg)	1200	1400	1600
1.6	Load center distance	c	(mm)	600	600	600
1.8	Load wheel axle to fork face (forks lowered)	x	(mm)	925	925	925
1.9	Wheelbase	y	(mm)	1610	1610	1610
<b>WEIGHT</b>						
2.1b	Truck weight without load, with maximum battery weight		kg	1175	1175	1175
2.2	Axle loadings with nominal load & maximum battery weight, drive / load side		kg	1030 / 1350	1115 / 1460	1200 / 1575
2.3	Axle loadings without load & with maximum battery weight, drive / load side		kg	840 / 335	840 / 335	840 / 335
<b>WHEELS, DRIVE TRAIN</b>						
3.1	Tyres			Vulkollan	Vulkollan	Vulkollan
3.2	Tyre dimensions, drive side		(mm)	230 x 70	230 x 70	230 x 70
3.3	Tyre dimensions, load side	ø	(mm)	85 x 90	85 x 75	85 x 75
3.4	Castor wheel dimensions (diameter x width)		(mm)	125 x 60	125 x 60	125 x 60
3.5	Number of wheels, load / drive side (x = driven)			1 + 1x / 2	1 + 1x / 4	1 + 1x / 4
3.6	Track width (center of tyres), drive side	b10	(mm)	515	515	515
3.7	Track width (center of tyres), load side	b11	(mm)	385	385	385
<b>DIMENSIONS</b>						
4.2b	Height with mast lowered	h1	(mm)	see tables	see tables	see tables
4.3	Free lift	h2	(mm)	see tables	see tables	see tables
4.4	Lift height	h3	(mm)	see tables	see tables	see tables
4.5	Height with mast extended	h4	(mm)	see tables	see tables	see tables
4.6	Initial lift	h5	(mm)	200	200	200
4.8	Seat- or stand height	h7	(mm)	175	175	175
4.9	Height of tiller arm/steering console (min / max)	h14	(mm)	1155 / 1550	1155 / 1550	1155 / 1550
4.15	Fork height, fully lowered	h13	(mm)	90	90	90
4.19	Overall length	l1	(mm)	2125 / 2605	2125 / 2605	2125 / 2605
4.2	Length to fork face	l2	(mm)	975 / 1455	975 / 1455	975 / 1455
4.21	Overall width	b1 / b2	(mm)	800	800	800
4.22	Fork dimensions (thickness, width, length)	s / e / l	(mm)	56 / 186 / 1150	56 / 186 / 1150	56 / 186 / 1150
4.24	Fork carriage width	b3	(mm)	750	750	750
4.25	Outside width over forks (minimum / maximum)	b5	(mm)	570	570	570
4.32	Ground clearance at center of wheelbase, (forks lowered)	m2	(mm)	20	20	20
4.33c	Working aisle width (Ast) with 1000 x 1200 mm pallets, load crosswise, platform up/down	Ast	(mm)	2743 / 3223	2743 / 3223	2743 / 3223
4.34c	Working aisle width (Ast3) with 800 x 1200 mm pallets, load lengthwise, platform up / down	Ast	(mm)	2657 / 3137	2657 / 3137	2657 / 3137
4.35	Turning radius	Wa	(mm)	1972 / 2452	1972 / 2452	1972 / 2452
<b>PERFORMANCE</b>						
5.1	Travel speed, with / without load		km / h	6.0 / 6.0	6.0 / 6.0	6.0 / 6.0
5.2	Lifting speed, with / without load		m / s	0.16 / 0.33	0.14 / 0.33	0.15 / 0.32
5.3	Lowering speed, with / without load		m / s	0.46 / 0.35	0.45 / 0.35	0.48 / 0.34
5.8	Maximum gradeability, with / without load		%	8 / 15	8 / 15	8 / 15
5.10	Service brakes (mechanical / hydraulic / electric / pneumatic)			Electric	Electric	Electric
<b>ELECTRIC MOTORS</b>						
6.1	Drive motor capacity (60 min. short duty)		kW	1	1	1
6.2	Lift motor output at 15% duty factor		kW	2.2	2.2	3.2
6.4	Battery voltage/capacity at 5-hour discharge		V / Ah	24 / 150 - 250	24 / 250	24 / 250 - 375
6.5	Battery weight		kg	210	210	210
6.6a	Energy consumption according to EN16796		kWh/h	0.77	0.78	0.78
<b>MISCELLANEOUS</b>						
8.1	Type of drive control			Stepless	Stepless	Stepless
10.7	Level of noise at the ear level of the driver according to EN 12 053:2001 and EN ISO 4871 in work LpAZ		dB (A)			
10.7.2	Whole-body vibration (EN 13 059:2002)			0.8	0.8	0.8
10.7.3	Hand-arm vibration (EN 13 059:2002)			< 2.5	< 2.5	< 2.5

# DIMENSIONS

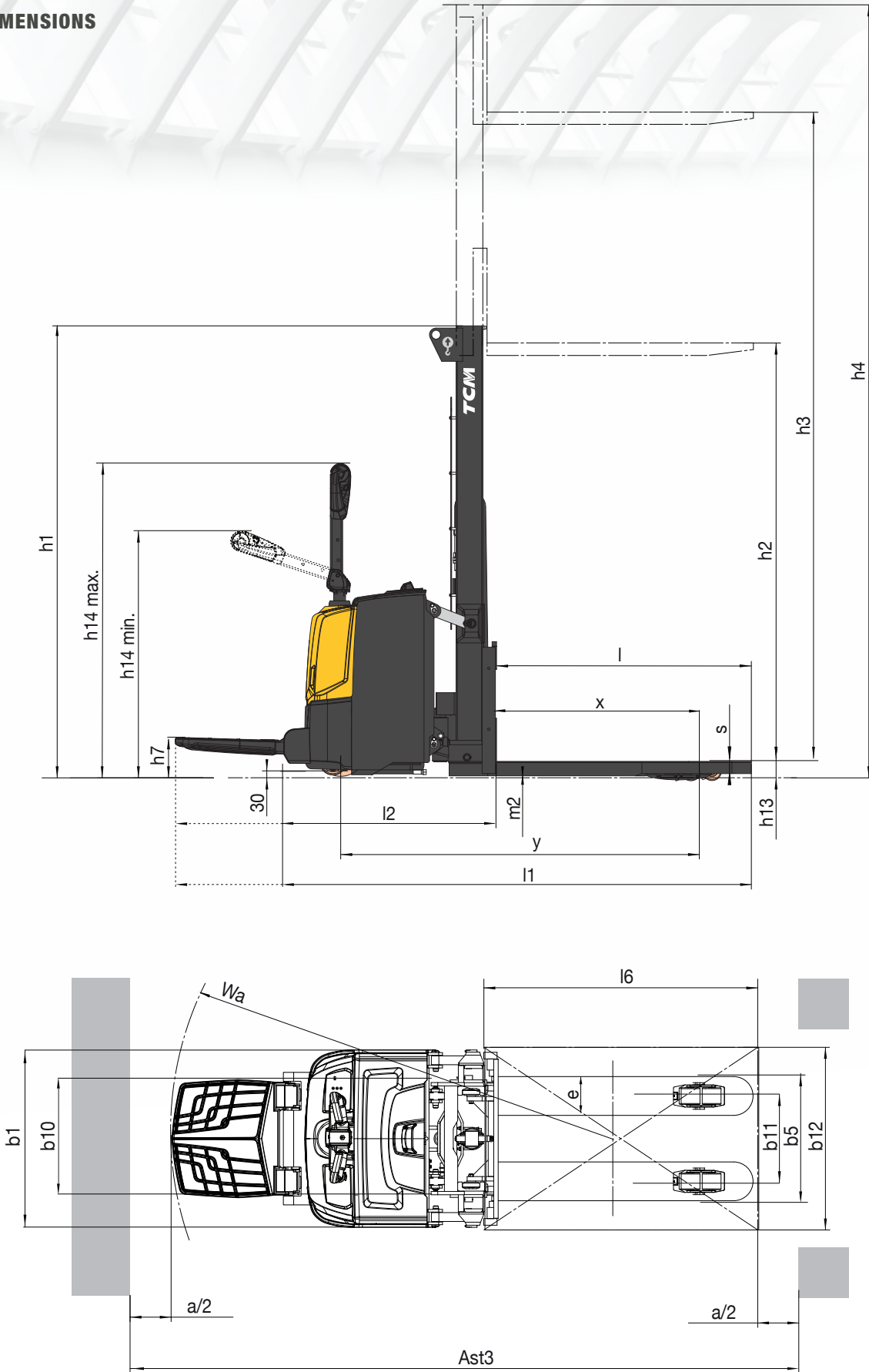

# SPR16S-N3

## STANDARD SPECIFICATIONS PRELIMINARY

CHARACTERISTICS				FOLDABLE PLATFORM WITHOUT INITIAL LIFT - WIDE STRADDLE
1.1	Manufacturer			TCM
1.2	Manufacturer's model designation			SPR16S-N3
1.3	Power source			Battery
1.4	Operator type			Pedestrian / Stand-on
1.5	Load capacity	Q	(kg)	1600
1.6	Load center distance	c	(mm)	600
1.8	Load wheel axle to fork face (forks lowered)	x	(mm)	750
1.9	Wheelbase	y	(mm)	1395
<b>WEIGHT</b>				
2.1b	Truck weight without load, with maximum battery weight		kg	1440
2.2	Axle loadings with nominal load & maximum battery weight, drive / load side		kg	1215 / 1985
2.3	Axle loadings without load & with maximum battery weight, drive / load side		kg	1020 / 420
<b>WHEELS, DRIVE TRAIN</b>				
3.1	Tyres			Vulkollan
3.2	Tyre dimensions, drive side		(mm)	230 x 70
3.3	Tyre dimensions, load side		(mm)	85 x 75
3.4	Castor wheel dimensions (diameter x width)		(mm)	125 x 60
3.5	Number of wheels, load / drive side (x = driven)			1 + 1x / 4
3.6	Track width (center of tyres), drive side	b10	(mm)	515
3.7	Track width (center of tyres), load side	b11	(mm)	1025-1425
<b>DIMENSIONS</b>				
4.2b	Height with mast lowered	h1	(mm)	see tables
4.3	Free lift	h2	(mm)	see tables
4.4	Lift height	h3	(mm)	see tables
4.5	Height with mast extended	h4	(mm)	see tables
4.8	Seat- or stand height	h7	(mm)	175
4.9	Height of tiller arm/steering console (min / max)	h14	(mm)	1155 / 1550
4.15	Fork height, fully lowered	h13	(mm)	85
4.19	Overall length	l1	(mm)	2085 / 2565
4.2	Length to fork face	l2	(mm)	935 / 1415
4.21	Overall width	b1 / b2	(mm)	800 / 1140 - 1575
4.22	Fork dimensions (thickness, width, length)	s / e / l	(mm)	40 / 100 / 1150
4.24	Fork carriage width	b3	mm)	980
4.25	Outside width over forks (minimum / maximum)	b5	(mm)	260 - 900
4.26	Inner width of support legs	b4	(mm)	900 - 1300
4.32	Ground clearance at center of wheelbase, (forks lowered)	m2	(mm)	20
4.33c	Working aisle width (Ast) with 1000 x 1200 mm pallets, load crosswise, platform up/down	Ast	(mm)	2690 / 3170
4.34c	Working aisle width (Ast3) with 800 x 1200 mm pallets, load lengthwise, platform up / down	Ast	(mm)	2690 / 3170
4.35	Turning radius	Wa	(mm)	1757 / 2237
<b>PERFORMANCE</b>				
5.1	Travel speed, with / without load		km / h	6.0 / 6.0
5.2	Lifting speed, with / without load		m / s	0.15 / 0.32
5.3	Lowering speed, with / without load		m / s	0.43 / 0.34
5.8	Maximum gradeability, with / without load		%	8 / 15
5.10	Service brakes (mechanical / hydraulic / electric / pneumatic)			Electric
<b>ELECTRIC MOTORS</b>				
6.1	Drive motor capacity (60 min. short duty)		kW	1
6.2	Lift motor output at 15% duty factor		kW	3.2
6.4	Battery voltage/capacity at 5-hour discharge		V / Ah	24 / 250 - 375
6.5	Battery weight		kg	210
6.6a	Energy consumption according to EN16796		kWh/ h	0.78
<b>MISCELLANEOUS</b>				
8.1	Type of drive control			Stepless
10.7	Level of noise at the ear level of the driver according to EN 12 053:2001 and EN ISO 4871 in work LpAZ		dB (A)	
10.7.2	Whole-body vibration (EN 13 059:2002)			0.8
10.7.3	Hand-arm vibration (EN 13 059:2002)			< 2.5

## DIMENSIONS

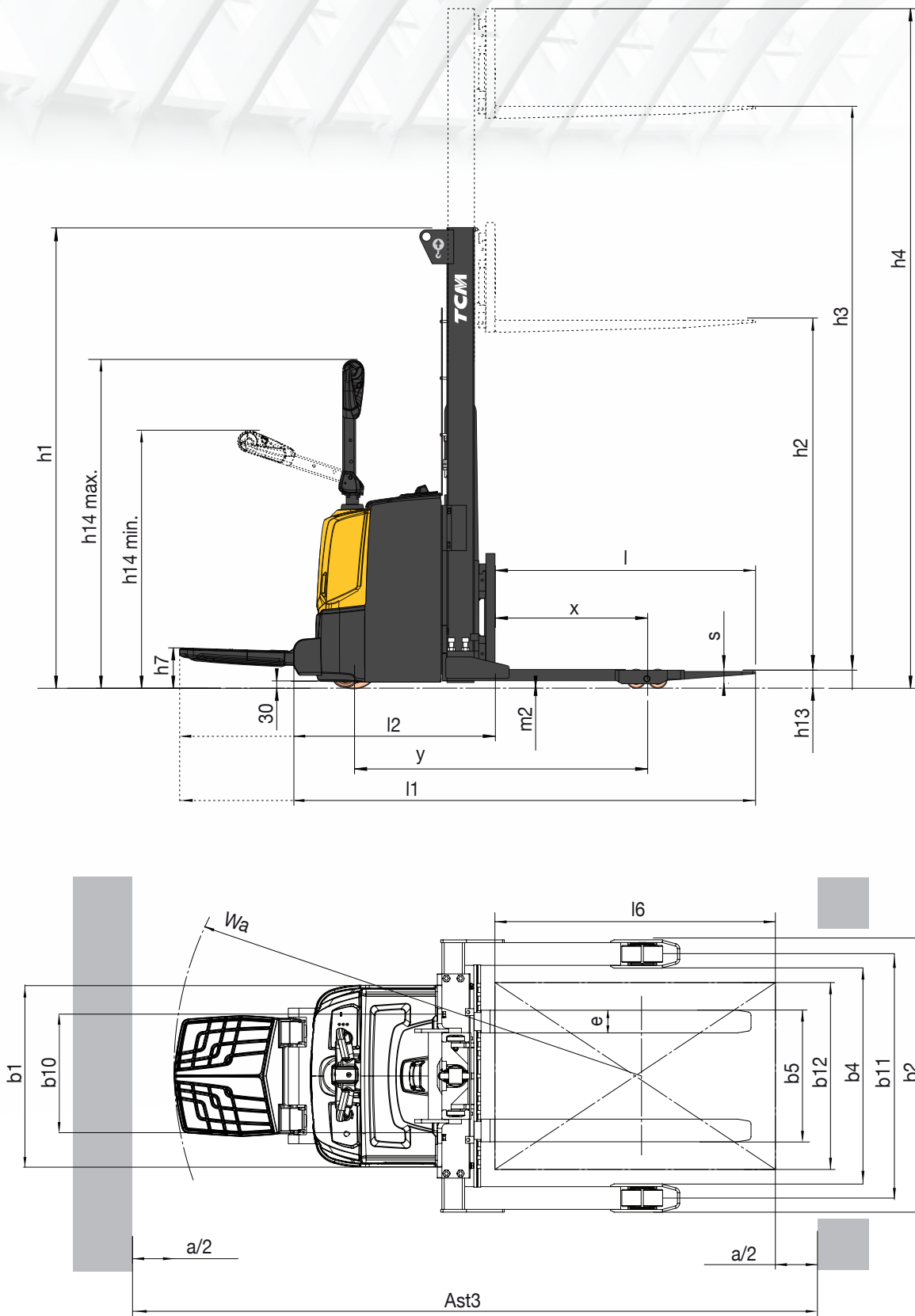

# SPW/SPR10-16(I)(S)-N3

## MAST SPECIFICATIONS

MAST TYPE	Lift height (mm)	Lowered mast height (mm)	Raised mast height (mm)	Freelift (mm)
	h3 + h13	h1	h4	h2 + h13

SPW/SPR10-N3				
1 STAGE	1500	1980	1980	1500
2 STAGE	2500	1775	3000	195
	2900	1975	3400	195
	3300	2175	3800	195

MAST TYPE	Lift height (mm)	Lowered mast height (mm)	Raised mast height (mm)	Freelift (mm)	Lowered mast height (mm)	Raised mast height (mm)	Freelift (mm)	Lowered mast height (mm)	Raised mast height (mm)	Freelift (mm)
	h3 + h13	h1	h4	h2 + h13	h1	h4	h2 + h13	h1	h4	h2 + h13

MAST TYPE	SPW/SPR12-16-N3				SPW/SPR12-16I-N3			SPW/SPR16S-N3			
	1 STAGE	1500	1950	1950	1500	2055	2055	1505	2030	2030	1500
2 STAGE	2500	1835	3000	200	1940	3105	200	1915	3080	195	
	2900	2035	3400	200	2140	3505	200	2115	3480	195	
	3300	2235	3800	200	2340	3905	200	2315	3880	195	
	3600	2385	4100	200	2490	4205	200	2465	4180	195	
	4300	2735	4800	200	2840	4905	200	2815	4880	195	
2 STAGE FULL FREE LIFT	2500	1775	2940	1355	1940	3105	1360	1915	3080	1355	
	2900	1975	3340	1555	2140	3505	1560	2115	3480	1555	
	3300	2235	3800	1755	2340	3905	1760	2315	3880	1755	
	3600	2385	4100	1905	2490	4205	1910	2465	4180	1905	
	4300	2735	4800	2255	2840	4905	2260	2815	4880	2255	
3 STAGE	4100	1955	4640	-	2060	4745	-	2035	4720	-	
	4300	2020	4840	-	2125	4945	-	2100	4920	-	
	4700	2153	5240	-	2260	5345	-	2233	5320	-	
	5400*	2385	5940	-	2490	6045	-	2465	6020	-	
3 STAGE FULL FREE LIFT	4100	1955	4640	1475	2060	4745	1480	2035	4720	1475	
	4300	2020	4840	1540	2125	4945	1545	2100	4920	1540	
	4700	2153	5240	1673	2260	5345	1673	2233	5320	1753	
	5400*	2385	5940	1905	2490	6045	1910	2465	6020	1905	

\* SPW/SPR14-16(I)-N3 Only





# SPW/SPR10-16(I)(S)-N3

## STANDARD AND OPTIONS LIST

	SPW/SPR10	SPW/SPR12	SPR/SPW12I	SPW/SPR14	SPW/SPR14I	SPW/SPR16	SPW/SPR16I	SPW/SPR16S
<b>GENERAL</b>								
Battery discharge indicator	●	●	●	●	●	●	●	●
PIN code login 4 codes	●	●	●	●	●	●	●	●
Multi-functional display with hour meter	●	●	●	●	●	●	●	●
Electric on/off valve for lifting and lowering, controlled by rocker switch on tiller head	●	●	●	●	●	●	●	●
Polyurethane drive wheel	●	●	●	●	●	●	●	●
Initial lift	-	-	●	-	●	-	●	-
Single load wheels polyurethane	●	-	●	-	-	-	-	-
Tandem load wheels polyurethane	●	●	●	●	●	●	●	●
Adjustable width between straddle load legs; 900mm - 1300mm	-	-	-	-	-	-	-	●
Sideways battery change (250Ah battery only)	-	●	●	●	●	●	●	●
Li-Ion batteries	●	●	●	●	●	●	●	●
<b>ENVIRONMENT</b>								
Cold store design, 0C° to -30C°	●	●	●	●	●	●	●	●
<b>DRIVE AND LIFT CONTROLS</b>								
Tiller up drive	●	●	●	●	●	●	●	●
<b>WHEEL OPTIONS</b>								
Polyurethane traction and load wheels	●	●	●	●	●	●	●	●
Power friction traction wheel	●	●	●	●	●	●	●	●
<b>OTHER OPTIONS</b>								
Speed reduction 0,5km/h above 1000 mm lift, duplex and triplex masts without free lift	-	●	●	●	●	●	●	●
Speed reduction 0,5km/h above free lift, duplex and triplex masts with free lift	-	●	●	●	●	●	●	●
Side stabilizers	-	-	-	-	-	●	-	-
Inbuilt charger, 30A	●	●	●	●	●	●	●	-
Key switch	●	●	●	●	●	●	●	●
Special RAL colour	●	●	●	●	●	●	●	●
Load backrest	●	●	●	●	●	●	●	●
Accessory rack	●	●	●	●	●	●	●	●
List bracket, A4 size	●	●	●	●	●	●	●	●

**KEY** ● Standard ● Option - Not available



**TCM**  
Always Evolving

info@tcm.eu | tcm.eu

Mitsubishi Logisnext Europe BV reserves the right to make any changes without notice concerning colours, equipment or specifications detailed in this brochure, or to discontinue individual models. The colours of vehicles delivered may differ slightly from those in this brochure. The specifications vary for different countries depending on local market conditions. Please consult your local dealer to ensure that the vehicle delivered accords with your expectations. All values are determined based on the standard condition and may vary, due to motor and system tolerances, condition of the truck and operational conditions. Some equipment shown on photos are optional. WEST2255