

We promise, We deliver

PSE10L-C
PSE15L-C
Walkie electric stacker

Noblelift Headquarters

Add:#528 Changzhou Road, Taihu
Sub-district, Changxing, 313100, China
TEL:+86 572 6210311/6120989
FAX:+86 572 6129336
WEB:www.noblelift.com
Email: info@noblelift.com



Official website



Our Wechat

Noblelift North America Corp.

Add:2461 S Wolf Road, Des Plaines, IL 60018
Tel:847-595-7100
Fax:847-595-7200
Email:sales@nobleliftna.com
Http: www.nobleliftna.com

Noblelift Europe GmbH

Add:Borsigstrasse 9d-93092 Barbing
Germany
TEL:+49 9401 607930
FAX:+49 9401 6079329
WEB:www.noblelifteuopr.com
Email: mail@noblelifteurope.com

Noblelift Russia

ООО "Ноблелифт Рус"
194292, Санкт-Петербург
Домостроительная ул. 4А офис 301
Бизнес-центр "Парнас"
тел.: +7 (800) 700-28-97
Email: sales@noblelift.com.ru



Long-tiller
Design



Capacity
1000-1500Kg



Easy
Maintenance



CURTIS
Technology



Powerful
Battery



Robust
Design



High
Maneuverability



Best Cost-Performance
Ratio

NEW Noblelift Products
ARRIVAL

NOBLELIFT INTELLIGENT EQUIPMENT CO., LTD

www.noblelift.com

PSE10L-C/PSE15L-C

Walkie electric stacker

PSE10L-C/PSE15L-C is an economic walkie electric stacker with rated capacity from 1000kg to 1500kg and lifting height from 1600 to 3600mm, which can meet most customers' requirements for goods stacking. The long-tiller design makes the operator comfortable and safer during operation.

ADVANTAGES

- High efficiency and energy saving, long service time.
- High power pump, high lifting efficiency.
- Compact and light design, easy operation.
- High stability, conform with safety standards.
- Strong channel mast provides the stacker with better stability and longer life.
- New appearance design, unified appearance of multiple specifications.

Long tiller design meets the requirements of ergonomics and safety

Long-tiller design ensures the operators' high efficiency and a safe distance from stacker. Compared with the short-tiller stacker, a long-tiller stacker uses less operating force. Besides, the safety distance and good view makes stacking operation more efficient and faster.



Maintenance-free lead-acid battery

Use maintenance-free lead-acid battery with deep discharge protection. (PSE10L-C 80Ah, PSE15L-C 100Ah)

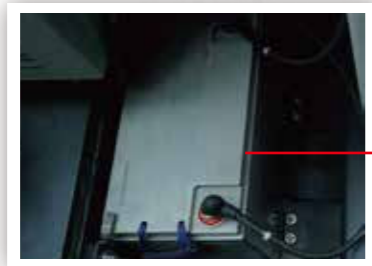

Stability casters

Convenient stability casters adjustment, no need for lifting the stacker.



Strong channel steel provides the stacker with better stability and longer life.

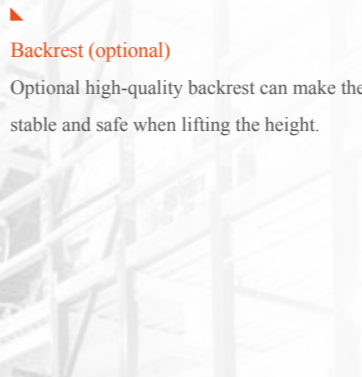

Backrest (optional)

Optional high-quality backrest can make the goods more stable and safe when lifting the height.



Multi-function meter

The multi-function meter can display the vehicle working status, battery power and working time. Proven emergency buttons and electricity meters are more durable and reliable than other vehicles. The battery discharge indicator has a low-voltage automatic cut-off and lifting function to ensure a longer service life of the battery. PSE10L-C has a built-in 10A charger; PSE15L-C has a built-in 15A charger.



PSE10L-C



PSE15L-C

Controller

PSE10-C adopts CAN-bus communication technology, which simplifies the circuit and enhances the reliability of the whole vehicle. PSE15L-C adopts analog quantity control technology, which has the advantages of intuitiveness, easy investigation and easy troubleshooting.

Debug interface

Lead out the car body through the debugging interface without removing the cover.

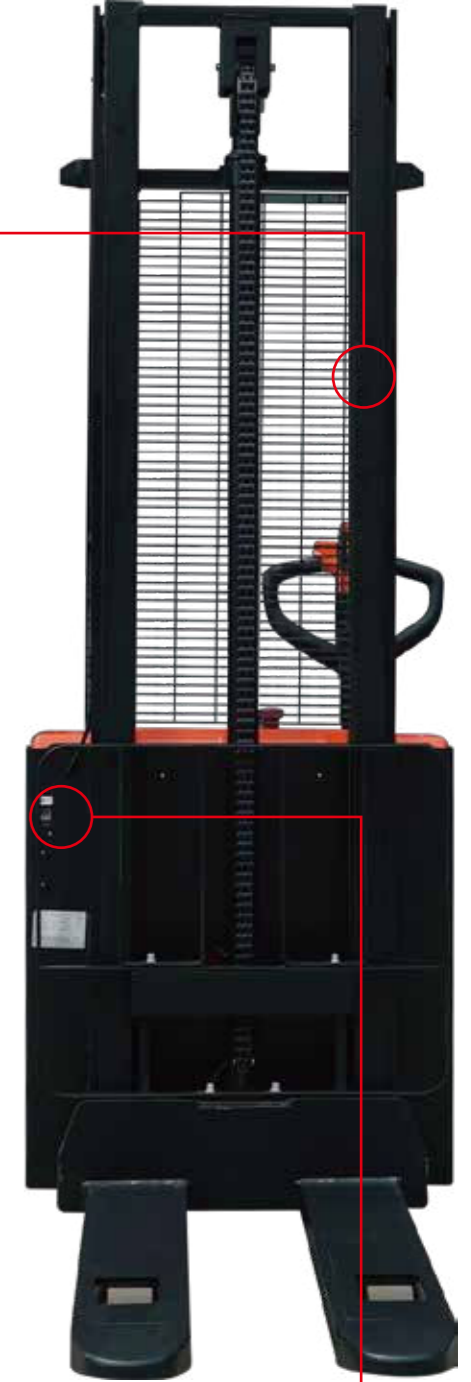

PSE10L-C

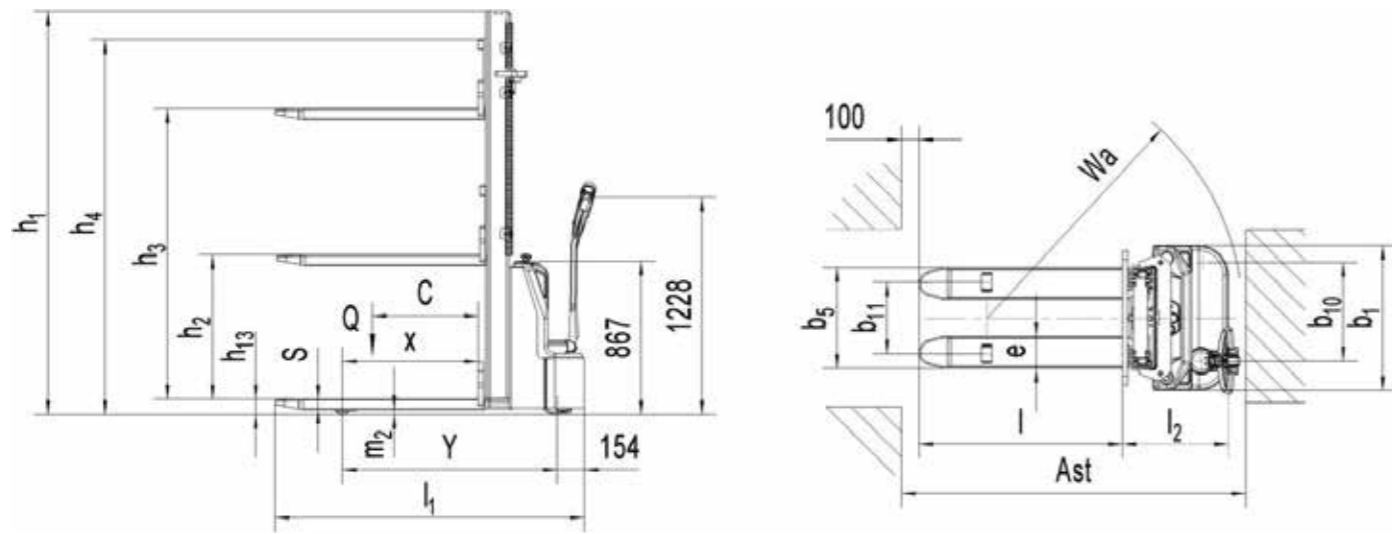

PSE15L-C

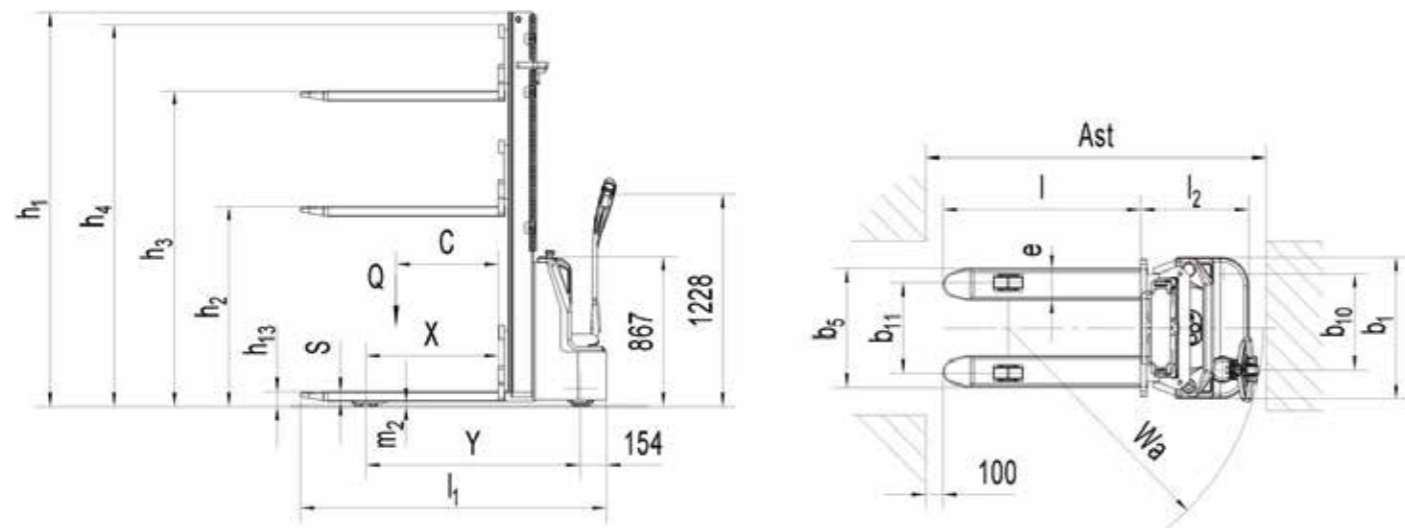

PSL Model (PSE10L-C)

Model	Lowered mast height h1 (mm)	Free lift height h2 (mm)	Lift height h3 (mm)	Extended mast height h4 (mm)	Lift+fork height h3+h13 (mm)
Single mast	2057	1513	1513	2057	1600
	2257	1913	1913	2257	2000
Double mast	1982	-	2813	3389	2900
	2132	-	3113	3689	3200
	2282	-	3413	3989	3500

PSL Model (PSE15L-C)

Model	Lowered mast height h1 (mm)	Free lift height h2 (mm)	Lift height h3 (mm)	Extended mast height h4 (mm)	Lift+fork height h3+h13 (mm)
Single mast	1980	1508	1513	1985	1600
	2380	1908	1913	2385	2000
Double mast	1932	78	2963	3339	2900
	2082	78	3113	3639	3200
	2282	78	3513	4039	3600

Type sheet for industrial truck acc. to VDI 2198

Distinguishing mark		PSL Model(PSE10L-C)		PSL Model (PSE15L-C)		
1.2	Manufacturer's type designation	1600	3500	1600	3600	
1.3	Drive	Battery		Battery		
1.4	Operator type	Pedestrian		Pedestrian		
1.5	Load capacity / rated load	Q (t) 1.0		1.5		
1.6	Load center distance	c (mm) 600		600		
1.8	Load distance ,centre of drive axle to fork	x (mm) 769		770		
1.9	Wheelbase	y (mm) 1215		1220	1245	
Weight						
2.1	Service weight	kg	450	570	590	750
2.2	Axle loading, laden front/rear	kg	490 / 960	540 / 1030	640 / 1450	690 / 1560
2.3	Axle loading, unladen front/ rear	kg	330 / 120	415 / 155	410 / 180	525 / 225
Tyres, Chassis						
3.1	Tires	Polyurethane (PU)		Polyurethane (PU)		
3.2	Tire size, front	Øxw (mm)	Ø 220x70	Ø 220x70		
3.3	Tire size, rear	Øxw (mm)	Ø 80x70	Ø 80x70		
3.4	Additional wheels(dimensions)	Øxw (mm)	Ø 100x50	Ø 100x50		
3.5	Wheels, number front/ rear(x=driven wheels)		1x+1/ 2	1x+1/ 2		
3.6	Tread, front	b10 (mm)	557	557		
3.7	Tread, rear	b11 (mm)	410 / 525	410 / 525		
Dimensions						
4.2	Lowered mast height	h1 (mm)	2057	2282	1980	2282
4.3	Free Lift height	h2 (mm)	1513	-	1508	78
4.4	lift	h3 (mm)	1513	3413	1513	3513
4.5	Extended maximal height	h4 (mm)	2057	3989	1985	4039
4.9	Height of tiller in drive position min./max.	h14 (mm)	670 / 1228		670 / 1228	
4.15	Height, lowered	h13 (mm)	87		87	
4.19	Overall length	l1 (mm)	1750		1779	
4.20	Length to face of forks	l2 (mm)	600		629	
4.21	Overall width	b1 (mm)	820		820	
4.22	Fork dimensions	s/e/l (mm)	60 / 180 / 1150		60 / 180 / 1150	
4.25	Width across forks	b5 (mm)	570 / 685		570 / 685	
4.32	Ground clearance, centre of wheelbase min./max.	m2 (mm)	32		27	
4.33	Aisle width for pallets 1000x1200 crossways	Ast (mm)	2293		2324	
4.34	Aisle width for pallets 800x1200 lengthwis	Ast (mm)	2238		2269	
4.35	Turning radius	Wa (mm)	1450		1481	
Performance data						
5.1	Travel speed, laden/ unladen	km/h	4.0/ 4.3		4.0/ 4.4	
5.2	Lift speed, laden/ unladen	m/s	0.119 / 0.195		0.087 / 0.148	
5.3	Lowering speed, laden/ unladen	m/s	0.166 / 0.159		0.125 / 0.117	
5.8	Max. gradeability, laden/ unladen	%	5 / 10		5 / 10	
5.10	Service brake		Electromagnetic		Electromagnetic	
Electric- motor						
6.1	Drive motor rating S2 60min	kW	0.75		0.75	
6.2	Lift motor rating at S3 7.5%	kW	2.2		2.2	
6.3	Battery acc. to DIN 43531/ 35/ 36 A, B, C, no		No		No	
6.4	Battery voltage, nominal capacity K5	V / Ah	2x12/80		2x12/100	
6.5	Battery weight	kg	2x26		2x34	
6.6	Energy consumption acc. to VDI cycle	kWh/h	0.44		0.68	
Addi- tional data						
8.1	Type of drive control		DC- Speed Control		DC- Speed Control	
8.4	Sound level at driver's ear acc. to EN 12053	dB(A)	<70		<70	