



Official website



Our Wechat

Noblelift Headquarters

Add:#528 Changzhou Road, Taihu
Sub-district, Changxing, 313100, China
TEL:+86 572 6210311/6120989
FAX:+86 572 6210777
WEB:www.noblelift.com
Email: info@noblelift.com

Noblelift North America Corp.

Add:2461 S Wolf Road, Des Plaines, IL 60018
Tel:847-595-7100
Fax:847-595-7200
Email:sales@nobleliftna.com
Http:www.nobleliftna.com

Noblelift Europe GmbH

Add:Borsigstrasse 9d-93092 Barbing
Germany
TEL:+49 9401 607930
FAX:+49 9401 6079329
WEB:www.noblelifteurop.com
Email: mail@noblelifteurop.com

Noblelift Russia

ООО "Ноблелифт Рус"
194292, Санкт-Петербург
Домостроительная ул. 4А офис 301
Бизнес-центр "Парнас"
тел.: +7 (800) 700-28-97
Email: sales@noblelift.com.ru



NOBLELIFT

Material Handling

EDGE series

Pallet Truck:

Li-ion Powered 1.2T- 1.5T- 2.0T & AGM 2.0T

Pallet Stacker:

Li-ion or AGM Powered 1.2T, Lift height: up to 3.6m



NOBLELIFT INTELLIGENT EQUIPMENT CO., LTD

www.noblelift.com

INTRODUCTION

The EDGE series was created by Noblift with the aim to supply product range which is capable to provide **high-efficient substitution** of manual and semi-electric equipment with **affordable cost**.

The family was named "Edge" thanks to new cutting-edge technical solutions which allowed us to create full range of **compact and smart** products.

Clear focus of every employer beside the working efficiency is the **reduction of safety risks and injuries** for employees. Majority of risks related to injuries of backs, caused by demand of high pulling and pushing force to move not powered equipment around, can be easily eliminated with the new EDGE products.

With consideration of performance increase and safety risk reduction, the **cost of ownership** for the products included to the EDGE family is actually lower than the one for manual and semi-electric equipment.

Smart features like speed control in turns, PIN-code or RFID access, function of driving with tiller in its vertical position, fast and opportunity charging for li-ion batteries, which before were not offered for economic material handling powered solutions, are now available for the Edge series products and making the work easier.

The EDGE series products are strictly conform to requirements of **international safety standards**.



PT ExxN PT ExxB PS ExxB PS ExxN

PT—Pallet Truck
 PS—Pallet Stacker
 E —Entry Level
 xx—Capacity (I.E. 1500kg=15)
 B —Basic Configuration (AGM)
 N —Standard Configuration (Lithium)

The EDGE Smart Design Pallet Trucks Family

Performance



DC 24V

PTE12N

● 1.2T Capacity **Li-ion**

- Perfect for light-duty applications.
- Compact & skeleton design
- Fast-charging Li-ion batteries.
- Ideal for occasional operations
- Easy-battery replacement
- High maneuverability



DC 24V

PTE15N

● 1.5T Capacity **Li-ion**

- Perfect for light-duty applications.
- Compact & sharp design
- Light service weight
- Fast-charging Li-ion batteries.
- Ideal for use on retail stores, lorries.
- Easy-battery replacement

Capacity



BLDC 48V

PTE20B

● 2.0T Capacity **AGM**

- Economic solution for heavy loads move
- Simple but robust skeleton design
- Maintenance-free Lead-acid Battery Pack
- Ideal for industrial applications
- Fast battery replacement
- Powerful drive & pump system



BLDC 48V

PTE20N

● 2.0T Capacity **Li-ion**

- Ultimate solution for heavy loads move
- Compact & robust design
- Fast-charging Li-ion batteries
- Easy-battery replacement
- Great grade-ability performance
- Powerful drive & pump system

Smart and Ergonomic Tillers

The Edge series trucks are configured with control tillers adopted to meet with application needs based on trucks designated performance.

Standard For PTE12N & PTE20B



Standard For PTE15N , Optional PTE12N & PTE20B



RFID Card Access is Standard for PTE20N optional for all other models

RFID card provides faster access to equipment and ideal for applications when one truck needs to be used by different operators



PTE12N

The tiller bar is supported by the air spring which helps to return the tiller to its vertical position without strike in the end point.

For increase of operation comfort and safety the trucks are equipped with speed reduction function in turns. (Optional for PTE12N and PTE15N, standard for other trucks)

The value of speed reduction is adjustable according to customers' preferences .

Compact Design and Vertical Driving

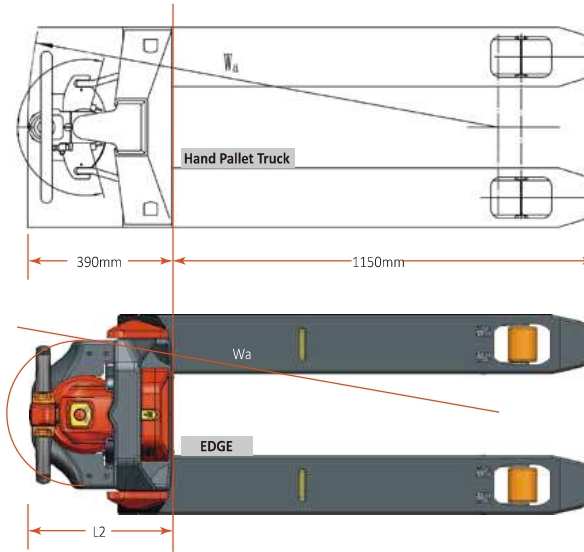

Model	Body length (L2)	Turning Radius	Weight
PTE12N	387mm	1337mm	124kg
PTE15N	380mm	1330mm	123kg
PTE20N	386mm	1336mm	149kg
PTE20B	478mm	1428mm	175kg

Our engineers put a lot of efforts to achieve compactness of the trucks in comparison with traditionally used manual and semi-electric products in order to provide full-electric solutions with high efficiency to replace old-fashioned low productive manual and semi-electric equipment and significantly reduce probability of injuries of operators caused by manual pumping or pushing/ pulling. At the same time, the service weight is minimized without compromising the robustness of the trucks esp. for delivery applications where the self-weight of the trucks is critical.



The function of driving with tiller in the **vertical position** helps with work in confined areas, especially in elevators and lorries without sacrificing of safety.



Smart & Replaceable Batteries for Pallet Trucks

The ***PTE xxN trucks** are equipped with maintenance-free Li-ion batteries, optional capacities for various applications are available, with its fast charging and opportunity charging features (charge whenever you want and as long as time allows) the operation time can be extended significantly.

All pallet trucks batteries are located in battery compartments securely, any possibility of movement is excluded, therefore the reliability of power supply is ensured.

*: xx=Capacity

Light weight of the battery (max. 8kg) and the easiest way of fast battery replacement allows even a female operator to double the working time within seconds. The light weight of the batteries can be achieved through use of Li-ion battery type with high ratio of energy density to its self-weight.



All Li-ion batteries are equipped with on-board Battery Management System (BMS), which provides mandatory control of all important parameters of the battery during charging and operation. With this control, the safety of Li-ion battery during the whole life-cycle is guaranteed. The Li-ion batteries are certified according to international safety transportation (by sea and by air) and operation standards. The BMS communicates with control system of the truck via CAN, the support of the CAN protocols allows to monitor the condition of the battery and make its diagnosis with help of special software which is available for our partners.



Optional different battery capacities from 20Ah to 36Ah for various applications

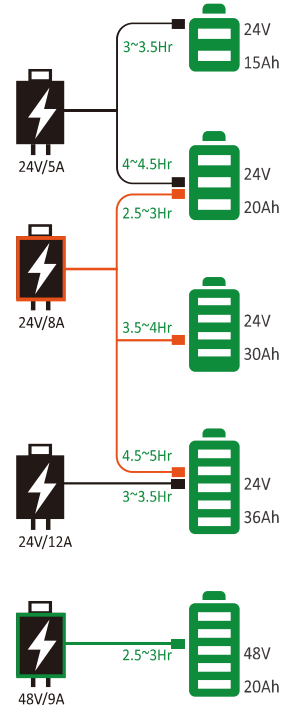

Manage your working time with selection of batteries and chargers



Socket on battery case for easy battery charging without necessity to take the battery out



The positioning of the battery inside the battery compartment is fast and easy thanks to specially designed battery guiding system



Battery cases for pallet trucks are made out of ABS PC material with 15% of glass fiber.

The ***PTE xxN trucks** remains unpowered while charger is connected with the battery charging socket even if the charger is disconnected from the power outlet, therefore, the safety is ensured and the possibility to damage the charger is excluded.

*: xx=Capacity

100% min. **2.5** hours charge | Excellent working time



The PTE 20B truck is equipped with maintenance-free AGM battery pack, the charging time is **8 hours**.

With the smart design, the battery pack can be replaced when it is necessary to double the operation time.



PTE15N



PTE20B

Gradeability Performance & Robustness



The Edge series trucks have great performance on ramps even when they are fully loaded regardless their economic positioning, each truck based on its performance level can climb on sufficient level of ramp, therefore, every customer can select the truck with consideration of particular working environment.

Model	PTE12N	PTE15N	PTE20N	PTE20B
Max. grade ability laden	4%	6%	7%	5%
Max. grade ability unladen	16%	16%	16%	16%

The frame of truck is surrounded by stamped steel elements making the truck looking different and also ensuring the **protection** of components for PTE15N and PTE20N



Forks of the truck with shape for easy entrance and exit from pallets for PTE15N, PTE20B and PTE20N.



Full length double sided C-shape **reinforcements** of forks significantly increase strength and **rigidity** of frame.



Strong steel apron **protects** the operator's feet during work and secures the truck's components from collisions with objects.



Maintenance Friendly

Drive motor with intelligent Curtis control



For the pallet trucks there are no hoses or pipes used in the hydraulic lifting circuit which significantly improves **reliability** and reduces the amount of potential problems related to leakages through connectors or their seals.

The trucks are equipped with **Curtis** controllers, **CAN-bus** technology makes the diagnostic and troubleshooting easier. **The use of proved and certified components helps to ensure the conformity to international safety standards with all the supporting documents available as required by law.**



Capacity	Ready	Min Volt	Max Volt
17.6%	24.50V	0mV	0mV
	0.00A	Avg Volt	Communication
		0.0mV	Normal

Realtime	Rated Capacity	Ah	Wh(Current)	0.0	Wh	Reset
	60.0			Discharge Cycle	Times	

Other		
Name	Value	Units
Cell Temp1	25.3	C
Cell Temp1	25.1	C
SOC	45	1/255
Power Temp	27.1	C
Envir Temp	32.2	C
Cell Volt Alarm	none	
Total Volt Alarm	none	
Current Alarm	none	
Temp Alarm	none	
Balance Alarm	none	

Volt		
Name	Value	Units
Cell	3507	mV
Total	24.5	V
Current	0.0	A
Run(Wh)	0	Wh

Each battery can be diagnosed via CAN connection with help of special software tool, the software can provide information about the battery condition such as balance of cells, amount of charging/discharging cycles, current, energy consumption, temperature, charging/discharging parameters, voltage of every cell, faults and alarms, settings of timing for automatic turn off.

The EDGE Smart Design Pallet Stackers

Performance

PSE12B

● 1.2T Capacity **AGM**

- Perfect for light-duty applications.
- Compact & light service weight
- High maneuverability
- Maintenance-free Lead-acid Battery
- Integrated on-board 12A charger
- Ideal for use on mezzanines

PSE12N

● 1.2T Capacity **Li-ion**

- Perfect for light-duty applications.
- Compact & light service weight
- High maneuverability
- Fast-charging Li-ion batteries.
- Integrated on-board 25A charger
- Ideal for use on mezzanines
- Ultimate solution for light duty operations



Smart and Ergonomic Tillers

Standard For PSE12B and PSE12N



RFID card Access

RFID Card Access is optional for PSE12B and standard for PSE12N

RFID card provides faster access to equipment and ideal for applications when one truck needs to be used by different operators



Vertical Driving in Confined Space



The function of driving with tiller in the **vertical position** helps with work in confined area without sacrificing of safety.

The tiller bar is supported by the air spring which helps to return the tiller to its vertical position without strike in the end point.

For increase of operation comfort and safety the trucks are equipped with speed reduction function in turns.



Smart Design with Compact Size and Perfect observation

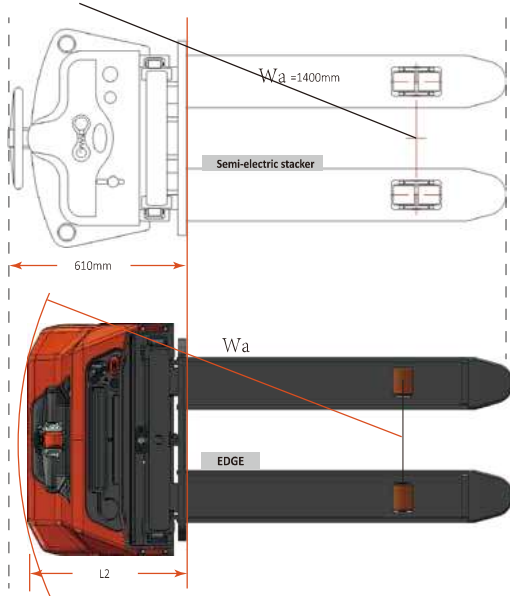

Model	PSE12B	PSE12N
length(L2)	560mm	560mm
Turning Radius	1350mm	1350mm

Our engineers put a lot of efforts to achieve compactness of the trucks in comparison with traditionally used manual and semi-electric products without sacrificing of stability, robustness, safety and operation comfort.



Wide mast provides perfect observation of forks, the field of view is clear and not interrupted by mast sections, cylinder or chains.



The operator can always clearly see the forks which significantly increases safety of operation



Gradeability Performance

Model	PSE12B	PSE12N
Max. grade ability laden	5%	5%
Max. grade ability unladen	10%	10%

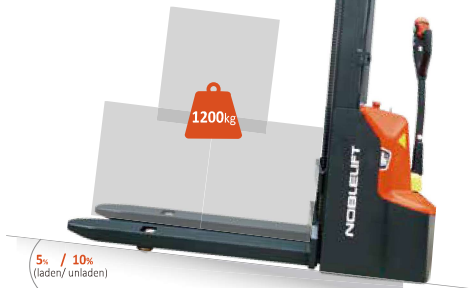

Robustness



Steel cover

The main cover is made out of steel with thickness 2.0mm



Tiller is made out of PA6 30% of glass fiber material, having high strength.

Capacity of 1200kg with high residual value at maximum height (load center distance 600 mm)

Real mast profiles are used for long life-time, no cheap bended solutions used. All directed to maintain performance of the truck during its life-cycle.



Welded forks are used to ensure robustness.

Maintenance Friendly

STANDARD CONFIGURATION & OPTIONS FOR EDGE FAMILY

Convenient and fast access to any component of the truck, no elements are located in areas difficult to reach. No Special tools are required.



Capacity		Ready	Min Volt	Max Volt
	24.50V	0mV	0mV	0mV
	0.00A	Avg Volt	Communication	Normal

Realtime				
Rated Capacity	60.0	Ah	Wh(Current)	0.0
Discharge Cycle Times	...		Discharge Cycle Times	...
			Wh	<input type="button" value="Reset"/>

Other		
Name	Value	Units
Cell Temp1	25.3	C
Cell Temp1	25.1	C
SOC	45	1/255
Power Temp	27.1	C
Envir Temp	32.2	C
Cell Volt Alarm	none	
Total Volt Alarm	none	
Current Alarm	none	
Temp Alarm	none	
Balance Alarm	none	

Volt		
Name	Value	Units
Cell	3507	mV
Total	24.5	V
Current	0.0	A
Run(Wh)	0	Wh

The software diagnostic tool for lithium batteries can provide full information about battery's condition and its current status. (The above values are for reference only.)

Battery Management System

CAN-bus

The BMS of battery controls charging and discharging parameters, working temperature, short circuits, has sleeping mode and is able to turn off the power in case of emergency. Communication with BMS and software adjustment is possible via CAN



The electric system is using CAN communication protocol increasing reliability of the system.

PSE12B
2x12 85Ah (5Hr) AGM maintenance free batteries are used.
Optionally available 2x12 106Ah (5Hr).

For PSE12B the charger with current 12A is used. The standard charging time is 7 hours

PSE12N
24V 60Ah Lithium LiFePO4 battery with BMS. Lithium battery has connection terminals with screws and located inside the steel case

For PSE12N the charger with current 25A is used. The standard charging time is 2.5 hours. Opportunity charging is supported

The PSE 12N stacker is equipped with maintenance-free 24V/60Ah LiFePO4 type Li-ion battery with fast charging and ultra-high number of charging /discharging cycles during life time; opportunity charging feature basically does not limit your operation time. The integrated BMS provides the same features as the BMS for the batteries of pallet trucks(refer to pallet truck section) .

The on-board charger with 25A current can provide full charge for less than 2.5 hours with great efficiency.

The **PSE 12B** stacker is equipped with 2x12V 85Ah VRLA-AGM maintenance free batteries. Optionally available 2x12V 105Ah batteries for longer operation.

The stacker is equipped with 12A on-board charger. The charging time is 7-8 hours, opportunity charging is not available.



STANDARD CONFIGURATION OR OPTIONS	PTE12N	PTE15N	PTE20N	PTE20B	PSE12B	PSE12N
Standard Battery	Li-ion 24V/15Ah	Li-ion 24V/20Ah	Li-ion 48V/20Ah	AGM 48V/20Ah	AGM 2x12V/85Ah	Li-ion 24V/60Ah
Li-ion Battery 24V/20Ah	0	S	—	—	—	—
Li-ion Battery 24V/30Ah	0	0	—	—	—	—
Li-ion Battery 24V/36Ah	0	0	—	—	—	—
AGM 2x12V/106Ah (5 Hr)	—	—	—	—	0	—
Standard Charger	24V / 5A	24V / 5A	48V / 9A	48V / 3A	24V / 12A	24V / 25A
Li-ion Charger 24V/5Ah	S	S	—	—	—	—
Li-ion Charger 24V/8Ah	with optional battery only	0	—	—	—	—
Li-ion Charger 24V/12Ah	with 36Ah battery only	with 36Ah battery only	—	—	—	—
Curtis controller	S	S	S	S	S	S
BMS	S	S	S	—	—	S
CAN-communication	S	S	S	S	S	S
Speed Reduction at Turning	0	0	S	S	S	S
Vertical drive/Pin wheel	S	S	S	S	S	S
Fast battery replacement	S	S	S	S	—	—
Entry Roller	S	S	S	S	—	—
Single Fork Roller	S	S	S	S	S	S
Tandem Fork Rollers	0	0	0	0	—	—
On-board charger	—	—	—	—	S	S
Stability Castors	0	0	S	S	S	S
High traction drive wheel tyre	0	0	—	—	—	—
Fork length 800/900/1000mm	0	0	0	0	—	—
Fork width 370/550/570mm	—	0	—	—	—	—
Load backrest(42/48/60")	—	0	0	—	—	—
Pin Code Access	0	S	S	0	S	S
RFID Access	0	0	S	0	—	0
LED Indicators on Tiller	S	—	—	S	—	—
LCD Display on Tiller	0	S	S	0	S	S

S=Standard O=Optional — =not available

Various Options(Pallet Truck)



Optional tandem fork rollers



Optional high traction drive wheel



Optional Stability Casters



Optional backrest

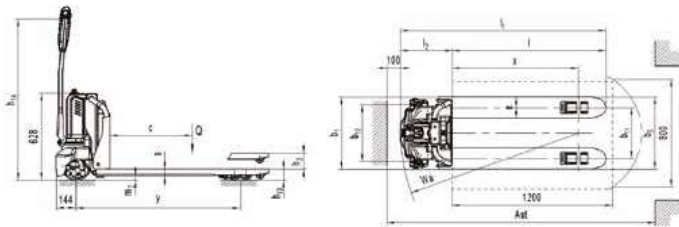

Type sheet for industrial truck acc. to VDI 2198

Distinguishing mark			
1.2	Manufacturer's type designation		PT E12N
1.3	Drive		Battery
1.4	Operator type		Pedestrian
1.5	Load Capacity / rated load	Q (t)	1.2
1.6	Load centre distance	c (mm)	600
1.8	Load distance ,centre of drive axle to fork	x (mm)	942
1.9	Wheelbase	y (mm)	1185
Weight			
2.1	Service weight	kg	124 129
2.2	Axle loading, laden front/rear	kg	355 / 972 425 / 908
2.3	Axle loading, unladen front/rear	kg	101 / 27 106 / 27
Tyres, chassis			
3.1	Tires		Polyurethane (PU)
3.2	Tire size, front	x w (mm)	210×70
3.3	Tire size, rear	x w (mm)	80×93(80×70)
3.4	Additional wheels(dimensions)	x w (mm)	-/ 80×30
3.5	Wheels,number front/rear(x=driven wheels)		1x/ 2(1x/ 4) or 1x +2/ 2(1x +2/ 4)
3.6	Tread, front	b ₀ (mm)	430
3.7	Tread, rear	b ₁ (mm)	380 525
Dimensions			
4.4	Lift height	h ₃ (mm)	115
4.9	Height of tiller in drive position min. / max.	h ₁₄ (mm)	700 / 1160
4.15	Height, lowered	h ₁₃ (mm)	80
4.19	Overall length	l ₁ (mm)	1537
4.20	Length to face of forks	l ₂ (mm)	387
4.21	Overall width	b ₁ (mm)	540 685
4.22	Fork dimensions	s/e/l (mm)	48 / 160 / 1150
4.25	Width across forks	b ₂ (mm)	540 685
4.32	Ground clearance, centre of wheelbase	m ₂ (mm)	32
4.34	Aisle width for pallets800X1200 lengthways (200mm safe distance)	Ast (mm)	2007
4.35	Turning radius	Wa (mm)	1337
Performance Data			
5.1	Travel speed, laden/ unladen	km/h	4.6/ 4.8
5.2	Lift speed, laden/ unladen	m/s	0.031 / 0.037
5.3	Lowering speed, laden/ unladen	m/s	0.069 / 0.051
5.8	Max. gradeability, laden/ unladen	%	4 / 16
5.10	Service brake		Electromagnetic
Electric- engine			
6.1	Drive motor rating S2 60min	kW	0.65
6.2	Lift motor rating at S3 10%	kW	0.50
6.3	Battery acc. to DIN 43531/ 35/ 36 A, B, C, no		No
6.4	Battery voltage, nominal capacity K5	V / Ah	24/15
6.5	Battery weight	kg	4.4
6.6	Energy consumption acc. to VDI cycle	kWh/h	0.14
Addition Data			
8.1	Type of drive control		DC speed Control
8.4	Sound level at driver's ear acc. to EN 12053	dB(A)	<70

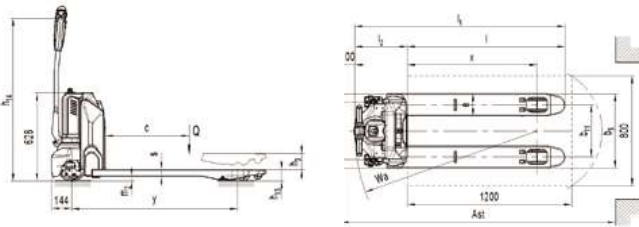

Type sheet for industrial truck acc. to VDI 2198

Distinguishing mark				
1.2	Manufacturer's type designation		PT E15N	PT E20N
1.3	Power(battery,diesel,petrol,gas>manual)		Battery	
1.4	Operator type		Pedestrian	
1.5	Load Capacity / rated load	Q (t)	1.5	2.0
1.6	Load centre distance	c (mm)	600	
1.8	Load distance ,centre of drive axle to fork	x (mm)	947	951
1.9	Wheelbase	y (mm)	1185	1189
Weight				
2.1	Service weight	kg	123 126 149 153	
2.2	Axle loading, laden front/rear	kg	623/1000 626/1000 621/1528 625/1528	
2.3	Axle loading, unladen front/rear	kg	96/27 99/27 115/34 119/34	
Tyres, chassis				
3.1	Tires		Polyurethane (PU)	
3.2	Tire size, front	x w (mm)	210×70	
3.3	Tire size, rear	x w (mm)	80×93(80×70)	
3.4	Additional wheels(dimensions)	x w (mm)	80×30	
3.5	Wheels,number front/rear(x=driven wheels)		1x/ 2(1x/ 4) or 1x +2/ 2(1x +2/ 4)	
3.6	Tread, front	b ₀ (mm)	430	
3.7	Tread, rear	b ₁ (mm)	380 525	380 525
Dimensions				
4.4	Lift height	h ₃ (mm)	115	
4.9	Height of tiller in drive position min. / max.	h ₁₄ (mm)	700 / 1160	
4.15	Height, lowered	h ₁₃ (mm)	80	
4.19	Overall length	l ₁ (mm)	1530	1536
4.20	Length to face of forks	l ₂ (mm)	380	386
4.21	Overall width	b ₁ (mm)	540 685	540 685
4.22	Fork dimension	s/e/l (mm)	47 / 160 / 1150	
4.25	Width across forks	b ₂ (mm)	540 685	540 685
4.32	Ground clearance, centre of wheelbase	m ₂ (mm)	33	
4.34	Aisle width for pallets800X1200 lengthways	Ast (mm)	2000	2006
4.35	Turning radius	Wa (mm)	1330	1336
Performance				
5.1	Travel speed, laden/ unladen	km/h	4.6/ 4.8	4.8/ 5.2
5.2	Lift speed, laden/ unladen	m/s	0.020 / 0.025	0.017 / 0.022
5.3	Lowering speed, laden/ unladen	m/s	0.05 / 0.04	0.05 / 0.03
5.8	Gradeability, laden/ unladen	%	6 / 16	7 / 16
5.10	Service brake		Electromagnetic	
Motors				
6.1	Drive motor rating S2 60min	kW	0.65	0.75
6.2	Lift motor rating at S3 10%	kW	0.50	0.8
6.3	Battery acc. to DIN 43531/ 35/ 36 A, B, C, no		/	
6.4	Battery voltage, nominal capacity K5	V / Ah	24/20(24/30;24/36)	48/20
6.5	Battery weight (minimum)	kg	4.6	7.5
6.6	Energy consumption acc. to VDI cycle	kWh/h	0.22	0.18
Addition Data				
8.1	Type of drive control		DC speed Control	
8.4	Sound level at driver's ear acc. to EN 12053	dB(A)	<70	

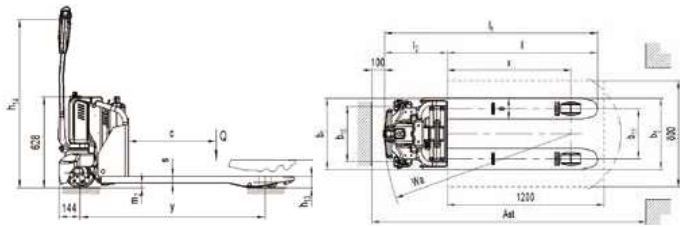

Type sheet for industrial truck acc. to VDI 2198

Distinguishing mark			
1.2	Manufacturer's type designation		PT E20B
1.3	Power(battery,diesel,petrol,gas>manual)		Battery
1.4	Operator type		Pedestrian
1.5	Load Capacity / rated load	Q (t)	2.0
1.6	Load centre distance	c (mm)	600
1.8	Load distance ,centre of drive axle to fork	x (mm)	946
1.9	Wheelbase	y (mm)	1281
Weight			
2.1	Service weight	kg	185 192
2.2	Axle loading, laden front/rear	kg	670 / 1515 673 / 1519
2.3	Axle loading, unladen front/rear	kg	145 / 40 152 / 40
Tyres, chassis			
3.1	Tires		Polyurethane (PU)
3.2	Tire size, front	x w (mm)	210×70
3.3	Tire size, rear	x w (mm)	80×93(80×70)
3.4	Additional wheels(dimensions)	x w (mm)	80×30
3.5	Wheels,number front/rear(x=driven wheels)		1x/ 2(1x/ 4) or 1x +2/ 2(1x +2/ 4)
3.6	Tread, front	b ₀ (mm)	430
3.7	Tread, rear	b ₁ (mm)	380 525
Dimensions			
4.4	Lift height	h ₃ (mm)	115
4.9	Height of tiller in drive position min. / max.	h ₁₄ (mm)	700 / 1160
4.15	Height, lowered	h ₁₃ (mm)	80
4.19	Overall length	l ₁ (mm)	1628
4.20	Length to face of forks	l ₂ (mm)	478
4.21	Overall width	b ₁ (mm)	540 685
4.22	Fork dimensions	s/e/l (mm)	47 / 160 / 1150
4.25	Width across forks	b ₂ (mm)	540 685
4.32	Ground clearance, centre of wheelbase	m ₂ (mm)	33
4.34	Aisle width for pallets800X1200 lengthways	Ast (mm)	2098
4.35	Turning radius	Wa (mm)	1428
Performance			
5.1	Travel speed, laden/ unladen	km/h	4.2/ 4.6
5.2	Lift speed, laden/ unladen	m/s	0.025 / 0.030
5.3	Lowering speed, laden/ unladen	m/s	0.075 / 0.063
5.8	Max. gradeability, laden/ unladen	%	5 / 16
5.10	Service brake		Electromagnetic
Motors			
6.1	Drive motor rating S2 60min	kW	0.75
6.2	Lift motor rating at S3 10%	kW	0.8
6.3	Battery acc. to DIN 43531/ 35/ 36 A, B, C, no		No
6.4	Battery voltage, nominal capacity K5	V / Ah	48/20
6.5	Battery weight (minimum)	kg	30
6.6	Energy consumption acc. to VDI cycle	kWh/h	0.19
Addition Data			
8.1	Type of drive control		DC speed Control
8.4	Sound level at driver's ear acc. to EN 12053	dB(A)	<70

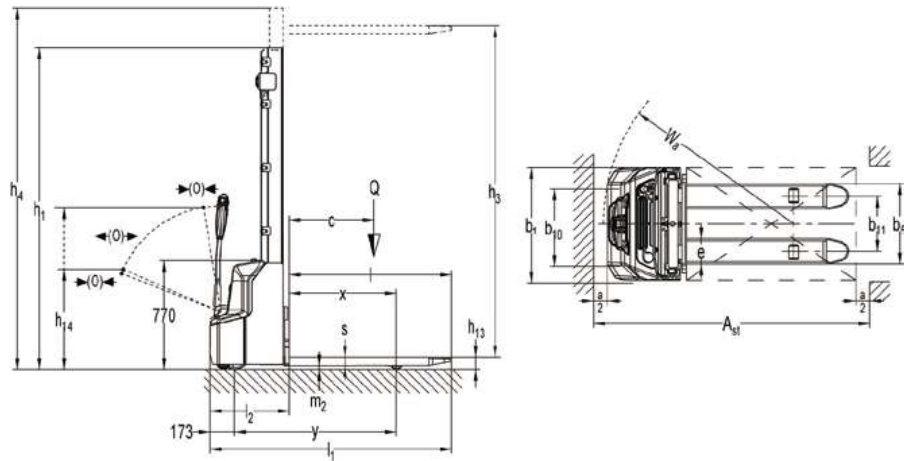

Mast table PSE 12B/PSE 12N

Designation	Lowered mast height h_1 (mm)	Free lift height h_2 (mm)	Lift height h_3 (mm)	Extended mast height h_4 (mm)	Lift + fork height $h_3 + h_{13}$ (mm)
Single-stage mast	1930	1514	1514	1930	1600
	2330	1914	1914	2330	2000
Two-stage mast	1780	-	2514	3037	2600
	1930	-	2814	3337	2900
	2080	-	3114	3637	3200
	2280	-	3514	4037	3600



Type sheet for industrial truck acc. to VDI 2198

Distinguishing mark		PS E12B	PS E12N
1.2	Manufacturer's type designation		3600
1.3	Power (battery ,diesel, petrol, gas, manual)		Battery
1.4	Operator type		Pedestrian
1.5	Load Capacity / rated load	Q (t)	1.2
1.6	Load centre distance	c (mm)	600
1.8	Load distance ,centre of drive axle to fork	x (mm)	760
1.9	Wheelbase	y (mm)	1147
Weight			
2.1	Service weight	kg	620
2.2	Axle loading, laden front/rear	kg	580 / 1240
2.3	Axle loading, unladen front/rear	kg	450 / 170
Tyres, chassis			
3.1	Tyres		Polyurethane
3.2	Tire size,front	x w (mm)	Φ 210×70
3.3	Tire size,rear	x w (mm)	Φ 84×93
3.4	Additional wheels(dimensions)	x w (mm)	Φ 100×50
3.5	Wheels,number front/rear(x=driven wheels)		1x + 1 / 2
3.6	Tread, front	b_{10} (mm)	550
3.7	Tread, rear	b_{11} (mm)	400 / 515
Dimensions			
4.2	Lowered mast height	h_1 (mm)	2280
4.3	Free Lift height	h_2 (mm)	—
4.4	Lift height	h_3 (mm)	3514
4.5	Extended mast height	h_4 (mm)	4037
4.9	Height of tiller in drive position min./ max.	h_{14} (mm)	710 / 1150
4.15	Height, lowered	h_{13} (mm)	86
4.19	Overall length	l_1 (mm)	1710
4.20	Length to face of forks	l_2 (mm)	560
4.21	Overall width	b_1 (mm)	800
4.22	Fork dimensions	s/e/l (mm)	60 / 180 / 1150
4.25	Distance between fork-arms	b_2 (mm)	570 / 685
4.32	Ground clearance, centre of wheelbase	m_2 (mm)	24
4.33	Aisle width for pallets 1000X1200 crossways	A_{st} (mm)	2197
4.34	Aisle width for pallets 800X1200 lengthways	A_{st} (mm)	2145
4.35	Turning radius	W_a (mm)	1350
Performance Data			
5.1	Travel speed, laden/ unladen	km/h	4.2/4.5
5.2	Lift speed, laden/ unladen	m/s	0.11/0.16
5.3	Lowering speed, laden/ unladen	m/s	0.13 / 0.11
5.8	Max. gradeability, laden/ unladen	%	5 / 10
5.10	Service brake		Electromagnetic
Electric-engine			
6.1	Drive motor rating S2 60min	kW	0.65
6.2	Lift motor rating at S3 4.5%	kW	2.2
6.3	Battery acc. to DIN 43531/35/36 A, B, C, no		No
6.4	Battery voltage, nominal capacity K5	V / Ah	2x12/85 ¹⁾
6.5	Battery weight +/-5%	kg	2x27 ²⁾
6.6	Energy consumption acc: to VDI cycle	kWh/h	0.8
Additional data			
8.1	Type of drive control		DC
8.4	Sound level at driver's ear acc. to EN 12053	dB(A)	<70

1) Option: 2x12V/106Ah
2) 2x12V/106Ah : 2 x 34