

4 Wheel 96V Electric Counterbalance Forklift

PRELIMINARY

TECHNICAL SPECIFICATIONS

FHB60-120(H)(/9)-E1



TCM
Always Evolving

FHB60-65(H)-E1

STANDARD SPECIFICATIONS PRELIMINARY

CHARACTERISTICS			TCM			
1.1	Manufacturer					
1.2	Manufacturer's model designation		FHB60-E1	FHB60H-E1	FHB65-E1	FHB65H-E1
1.3	Power source: (battery, diesel, LPG, petrol)		Battery	Battery	Battery	Battery
1.4	Operator type: pedestrian, (operator) - standing, - seated		Seated	Seated	Seated	Seated
1.5	Load capacity	Q	(kg) 6000	6000	6500	6500
1.6	Load center distance	c	(mm) 600	600	600	600
1.8	Load wheel axle to fork face	x	(mm) 650	650	650	650
1.9	Wheelbase	y	(mm) 2550	2550	2550	2550
WEIGHT						
2.1	Truck weight without load, with maximum battery weight		kg 10260	10260	10430	10430
2.2	Axle loading with maximum load, front / rear (simple x mast, lowest lift height)		kg 14523 / 1737	14523 / 1737	15316 / 1614	15316 / 1614
2.3	Axle loading without load, front / rear (simple x mast, lowest lift height)		kg 5190 / 5070	5190 / 5070	5200 / 5230	5200 / 5230
WHEELS, DRIVE TRAIN						
3.1	Tyres: V = solid, L = pneumatic, SE = solid pneumatic - front / rear		SE	SE	SE	SE
3.2	Tyre dimensions, front		8.25-15	8.25-15	8.25-15	8.25-15
3.3	Tyre dimensions, rear		22 x 9 -16 23 x 10-12	22 x 9 -16 23 x 10-12	22 x 9 -16 23 x 10-12	22 x 9 -16 23 x 10-12
3.5	Number of wheels, front / rear (x = driven)		2x / 2	2x / 2	2x / 2	2x / 2
3.6	Track width (centre of tyres), front	b10	(mm) 1305 1375 1380	1306 1375 1380	1307 1375 1380	1308 1375 1380
3.7	Track width (centre of tyres), rear	b11	(mm) 1220 1225	1221 1225	1222 1225	1223 1225
DIMENSIONS						
4.1	Mast tilt, forwards / backwards	α / β	° 5.5 / 6	5.5 / 6	5.5 / 6	5.5 / 6
4.2	Height with mast lowered	h1	(mm) 2680	2680	2680	2680
4.3	Free lift	h2	(mm) 100	100	100	100
4.4	Lift height	h3	(mm) 3400	3400	3400	3400
4.5	Overall height with mast raised	h4	(mm) 4370	4370	4370	4370
4.7	Height to top of overhead guard	h6	(mm) 2420	2420	2420	2420
4.8	Seat height	h7	(mm) 1330	1330	1330	1330
4.12	Tow coupling height	h10	(mm) 465	465	465	465
4.19	Overall length	l1	(mm) 4550	4550	4550	4550
4.2	Length to fork face (includes fork thickness)	l2	(mm) 3300	3300	3300	3300
4.21	Overall width	b1 / b2	(mm) 1660 / 1830	1661 / 1830	1662 / 1830	1663 / 1830
4.22	Fork dimensions (thickness, width, length)	s / e / l	(mm) 150 x 60 x 1200	150 x 60 x 1200	150 x 60 x 1200	150 x 60 x 1200
4.23	Fork carriage iso 2328 / 30, FEM / A/B		4A	4A	4A	4A
4.24	Fork carriage width	b3	(mm) 1300	1300	1300	1300
4.31	Ground clearance under mast, with load	m1	(mm) 180	180	180	180
4.32	Ground clearance at center of wheelbase, (forks lowered)	m2	(mm) 165	165	165	165
4.33	Working aisle width with 1000 x 1200 mm pallets, crosswise	Ast	(mm) 4835	4610	4835	4610
4.34a	Working aisle width with 800 x 1200 mm pallets, load crosswise	Ast	(mm) -	-	-	-
4.34b	Working aisle width with 800 x 1200 mm pallets, load lengthwise	Ast	(mm) 5035	4745	5035	4745
4.35	Turning circle radius	Wa	(mm) 2985	2650	2985	2650
4.36	Minimum distance between centres of rotation	b13	(mm) 950	-	950	-
PERFORMANCE						
5.1	Travel speed, with / without load	km / h	15 / 15	20 / 20	15 / 15	20 / 20
5.2	Lifting speed, with / without load	m / s	0.24 / 0.39	0.24 / 0.40	0.24 / 0.41	0.24 / 0.42
5.3	Lowering speed, with / without load	m / s	0.5 / 0.4	0.39 / 0.45	0.5 / 0.6	0.37 / 0.45
5.5	Rated drawbar pull, with / without load	N	6900 / 7500	6900 / 7500	6900 / 7500	6900 / 7500
5.6	Maximum drawbar pull, with / without load (5 min short duty)	N	16400 / 17000	23800 / 24400	16400 / 17000	23700 / 24300
5.7	Gradeability, with / without load	%	6.5 / 11	8.2 / 13.5	6.5 / 11	7.9 / 12.8
5.8	Maximum gradeability with / without load	%	10 / 16	14.7 / 23.7	10 / 16	14.2 / 22.5
5.9	Acceleration time (10 metres) with / without load	s	5.8 / 5.4	6.6 / 5.3	5.8 / 5.4	6.6 / 5.3
5.1	Service brakes (mechanical / hydraulic / electric / pneumatic)		electric	hydraulic / electric	electric	hydraulic / electric
ELECTRIC MOTOR						
6.1	Drive motor capacity (60 min. short duty)	kW	2 x 15	2 x 15	2 x 15	2 x 15
6.2	Lift motor output at 15% duty factor	kW	30	30	30	30
6.3	Battery to DIN 43 531 / 35 / 36 A / B / C / no		-	-	-	-
6.4	Battery voltage	V / Ah	96	96	96	96
6.5	Battery weight (including container)	kg	3350	3350	3350	3350
6.6a	Energy consumption according to DIN EN 16796	kWh / h	-	-	-	-
6.6b	Energy consumption acc. to VDI cycle	kWh / h	-	-	-	-
MISCELLANEOUS						
8.1	Type of drive control		inverter	inverter	inverter	inverter
10.1	Maximum operating pressure for attachments	bar	200	200	200	200
10.2	Oil flow for attachments	l / min	-	-	-	-
10.7	Noise level, value at operator's ear (EN 12053)	dB (A)	-	-	-	-
10.8	Towing coupling, type DIN 15170		72	72	72	72

DIMENSIONS FHB60-65(H) -E1

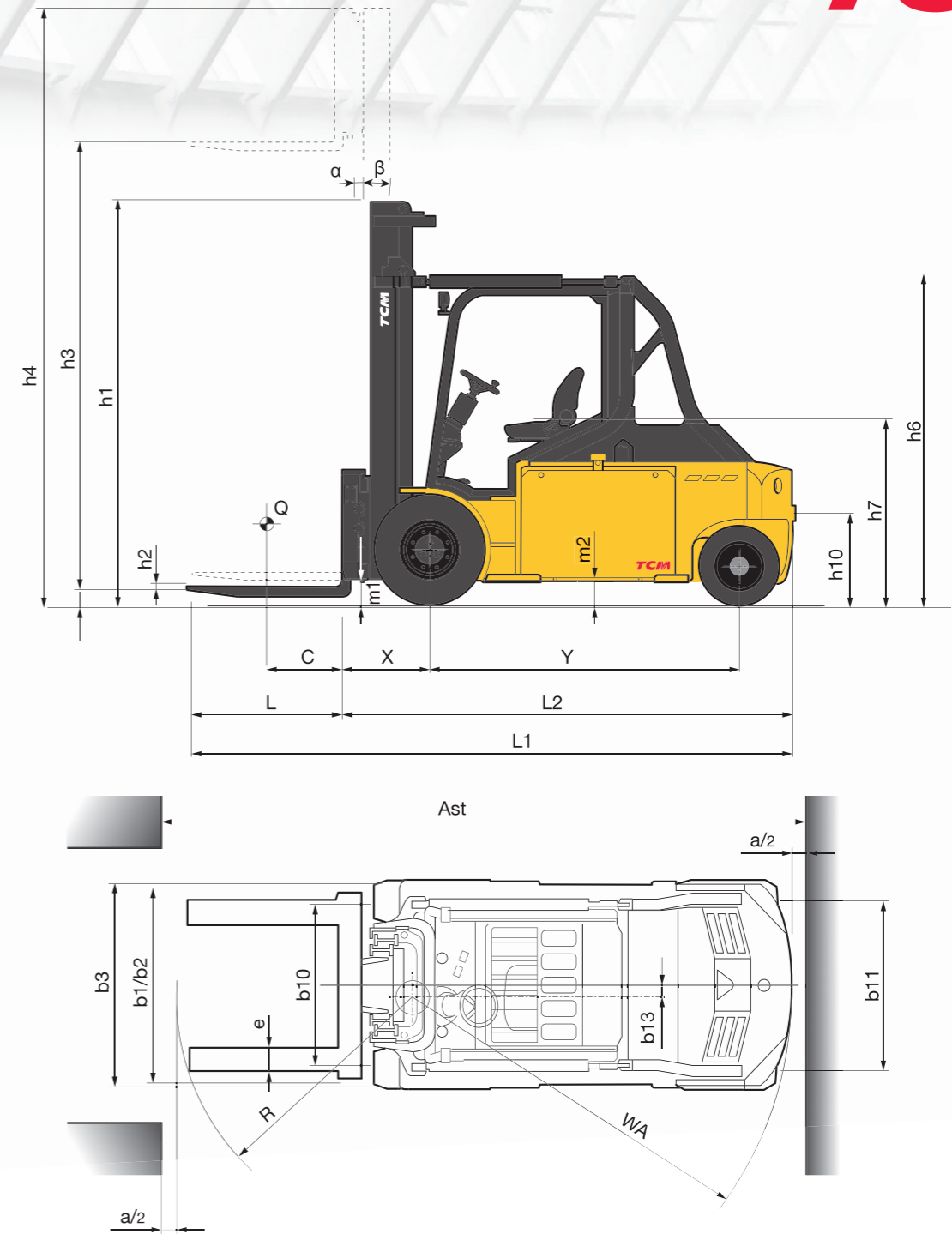

MAST LIFT HEIGHT CAPACITIES

Max fork height (mm)	FHB60(H)-E1						FHB65(H)-E1						
	Sideshift			Side shifting fork positioner			Sideshift			Side shifting fork positioner			
	Load Capacity (kgs) @ load centre (mm)												
	600	900	1200	600	900	1200	600	900	1200	600	900	1200	
SINGLE stage mast	3400	6000	5200	4000	5800	5000	4000	6500	5300	4000	6300	5100	4000
	3800	6000	5150	4000	5800	4950	3950	6500	5300	4000	6300	5100	4000
	4200	6000	5000	4000	5800	4800	3850	6300	5150	4000	6100	4950	4000
	4500	5900	4850	4000	5700	4650	3750	6100	5000	4000	5900	4800	3900
	5500	5500	4500	3800	5300	4300	3550	5700	4700	4000	5500	4500	3800
DOUBLE and TRIPLE stage mast	4380	6000	5000	4000	5800	4800	3900	6200	5200	4000	6000	5000	4000
	5300	5500	4600	3850	5300	4400	3650	5650	4800	4000	5450	4600	3950
	5500	5400	4500	3800	5200	4300	3550	5600	4750	4000	5400	4550	3850
	5700	5300	4400	3750	5100	4200	3500	5500	4650	4000	5300	4450	3750
	6100	5200	4300	3650	5000	4100	3400	5350	4500	3800	5150	4300	3600

FHB70-80(H)-E1

STANDARD SPECIFICATIONS PRELIMINARY

CHARACTERISTICS			TCM			
			FHB70-E1	FHB70H-E1	FHB80-E1	FHB80H-E1
1.1	Manufacturer					
1.2	Manufacturer's model designation					
1.3	Power source: (battery, diesel, LPG, petrol)		Battery	Battery	Battery	Battery
1.4	Operator type: pedestrian, (operator) - standing, - seated		Seated	Seated	Seated	Seated
1.5	Load capacity	Q (kg)	7000	7000	8000	8000
1.6	Load center distance	c (mm)	600	600	600	600
1.8	Load wheel axle to fork face	x (mm)	650	650	700	700
1.9	Wheelbase	y (mm)	2250	2250	2550	2550
WEIGHT						
2.1	Truck weight without load, with maximum battery weight	kg	10770	10770	12095	12095
2.2	Axle loading with maximum load, front / rear (simple x mast, lowest lift height)	kg	16124 / 1646	16124 / 1646	18670 / 1425	18670 / 1425
2.3	Axle loading without load, front / rear (simple x mast, lowest lift height)	kg	5240 / 5530	5240 / 5530	6590 / 5505	6590 / 5505
WHEELS, DRIVE TRAIN						
3.1	Tyres: V = solid, L = pneumatic, SE = solid pneumatic - front / rear		SE	SE	SE	SE
3.2	Tyre dimensions, front		8.25-15	8.25-15	8.25-15	8.25-15
3.3	Tyre dimensions, rear		22 x 9 -16 23 x 10-12	22 x 9 -16 23 x 10-12	22 x 9 -16 23 x 10-12	22 x 9 -16 23 x 10-12
3.5	Number of wheels, front / rear (x = driven)		2x / 2	2x / 2	2x / 2	2x / 2
3.6	Track width (centre of tyres), front	b10 (mm)	1309 1375 1380	1310 1375 1380	1311 1375 1380	1312 1375 1380
3.7	Track width (centre of tyres), rear	b11 (mm)	1224 1225	1225 1225	1226 1225	1227 1225
DIMENSIONS						
4.1	Mast tilt, forwards / backwards	α / β (°)	5.5 / 6	5.5 / 6	5.5 / 6	5.5 / 6
4.2	Height with mast lowered	h1 (mm)	2680	2680	2792	2792
4.3	Free lift	h2 (mm)	100	100	0	0
4.4	Lift height	h3 (mm)	3400	3400	3400	3400
4.5	Overall height with mast raised	h4 (mm)	4370	4370	4530	4530
4.7	Height to top of overhead guard	h6 (mm)	2420	2420	2420	2420
4.8	Seat height	h7 (mm)	1330	1330	1330	1330
4.12	Tow coupling height	h10 (mm)	465	465	465	465
4.19	Overall length	l1 (mm)	4550	4550	4840	4840
4.2	Length to fork face (includes fork thickness)	l2 (mm)	3300	3300	3640	3640
4.21	Overall width	b1 / b2 (mm)	1664 / 1830	1665 / 1830	1666 / 1830	1667 / 1830
4.22	Fork dimensions (thickness, width, length)	s / e / l (mm)	150 x 60 x 1200	150 x 60 x 1200	200 x 60 x 1200	200 x 60 x 1200
4.23	Fork carriage iso 2328 / 30, FEM / A/B		4A	4A	4A	4A
4.24	Fork carriage width	b3 (mm)	1300	1300	1300	1300
4.31	Ground clearance under mast, with load	m1 (mm)	180	180	180	180
4.32	Ground clearance at center of wheelbase, (forks lowered)	m2 (mm)	165	165	165	165
4.33	Working aisle width with 1000 x 1200 mm pallets, crosswise	Ast (mm)	4835	4610	5200	4955
4.34a	Working aisle width with 800 x 1200 mm pallets, load crosswise	Ast (mm)	-	-	-	-
4.34b	Working aisle width with 800 x 1200 mm pallets, load lengthwise	Ast (mm)	5035	4745	5400	5095
4.35	Turning circle radius	Wa (mm)	2985	2650	3300	2950
4.36	Minimum distance between centres of rotation	b13 (mm)	950	-	1050	-
PERFORMANCE						
5.1	Travel speed, with / without load	km / h	14.5 / 15	20 / 20	14 / 15	19 / 20
5.2	Lifting speed, with / without load	m / s	0.22 / 0.39	0.22 / 0.39	0.2 / 0.34	0.2 / 0.35
5.3	Lowering speed, with / without load	m / s	0.5 / 0.8	0.35 / 0.45	0.45 / 0.35	0.31 / 0.45
5.5	Rated drawbar pull, with / without load	N	6600 / 7300	6600 / 7300	6400 / 7200	6400 / 7200
5.6	Maximum drawbar pull, with / without load (5 min short duty)	N	16100 / 16800	23600 / 24300	15900 / 16700	23000 / 24400
5.7	Gradeability, with / without load	%	5.5 / 10	7.4 / 12.8	5 / 9.5	6.4 / 11.1
5.8	Maximum gradeability with / without load	%	8.5 / 14	13.4 / 22.5	8 / 13.5	11.6 / 19.6
5.9	Acceleration time (10 metres) with / without load	s	6.1 / 5.7	7 / 5.5	6.2 / 5.8	7.4 / 5.6
5.1	Service brakes (mechanical / hydraulic / electric / pneumatic)		electric	hydraulic / electric	electric	hydraulic / electric
ELECTRIC MOTOR						
6.1	Drive motor capacity (60 min. short duty)	kW	2 x 15	2 x 15	2 x 15	2 x 15
6.2	Lift motor output at 15% duty factor	kW	30	30	30	45
6.3	Battery to DIN 43 531 / 35 / 36 A / B / C / no		-	-	-	-
6.4	Battery voltage	V / Ah	96	96	96	96
6.5	Battery weight (including container)	kg	3350	3350	4300	4300
6.6a	Energy consumption according to DIN EN 16796	kWh / h	-	-	-	-
6.6b	Energy consumption acc. to VDI cycle	kWh / h	-	-	-	-
MISCELLANEOUS						
8.1	Type of drive control		inverter	inverter	inverter	inverter
10.1	Maximum operating pressure for attachments	bar	200	200	200	200
10.2	Oil flow for attachments	l / min	-	-	-	-
10.7	Noise level, value at operator's ear (EN 12053)	dB (A)	-	-	-	-
10.8	Towing coupling, type DIN 15170		72	72	72	72

DIMENSIONS FHB70-80(H)-E1

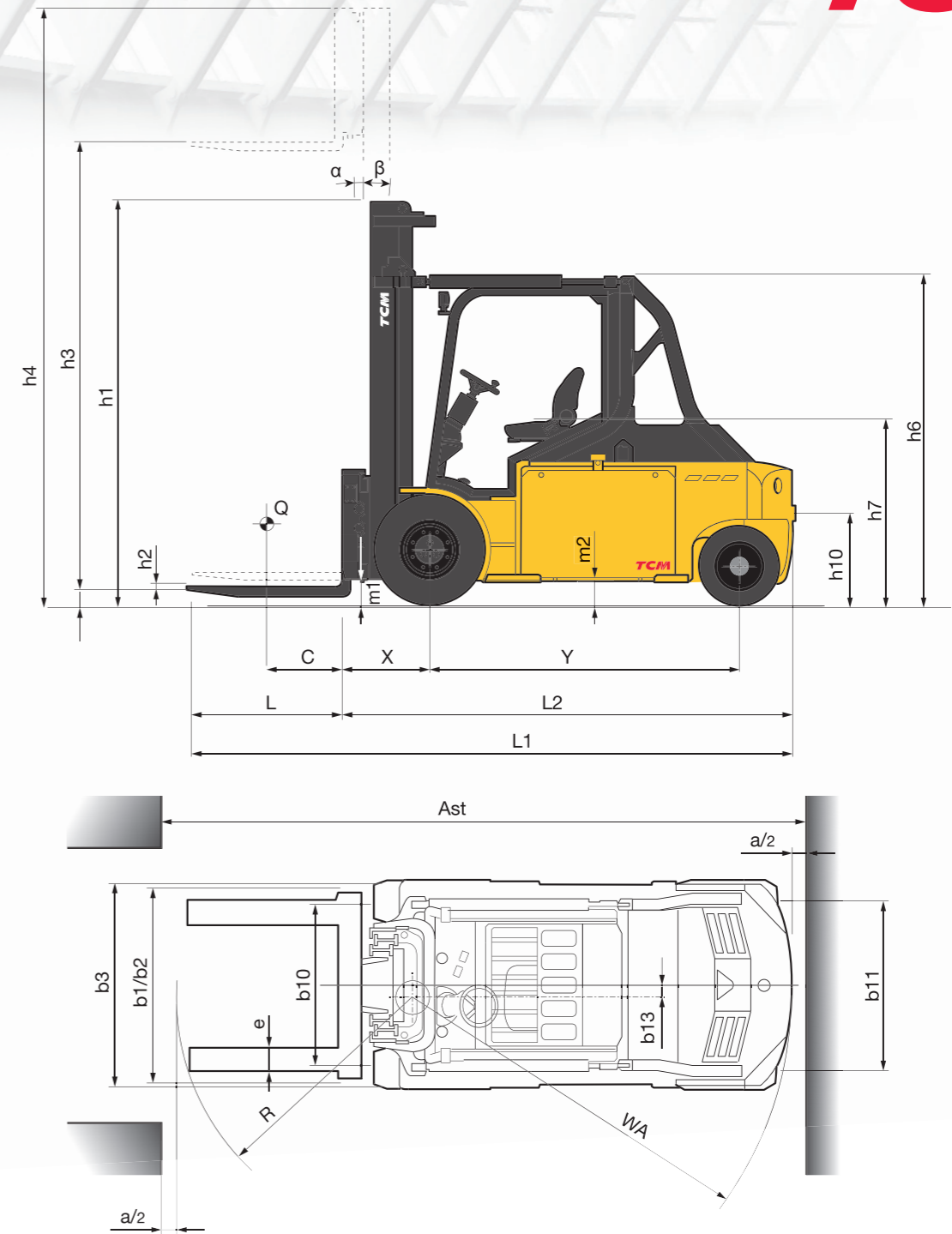

MAST LIFT HEIGHT CAPACITIES

	Max fork height (mm)	FHB70(H)-E1						FHB80(H)-E1					
		Sideshift			Side shifting fork positioner			Sideshift			Side shifting fork positioner		
		Load Capacity (kgs) @ load centre (mm)											
		600	900	1200	600	900	1200	600	900	1200	600	900	1200
SINGLE stage mast	3400	7000	5300	4000	6800	5300	4000	8000	6300	5100	7800	6100	4900
	3800	6850	5300	4000	6650	5300	4000	7700	6200	5050	7500	6000	4850
	4200	6700	5300	4000	6500	5300	4000	7400	6000	5050	7200	5800	4850
	4500	6500	5300	4000	6300	5150	4000	7100	5750	4900	6900	5550	4700
DOUBLE and TRIPLE stage mast	5500	6100	4900	4000	5900	4700	4000	6700	5500	4700	6500	5300	4500
	4380	6550	5300	4000	6350	5100	4000	7000	5800	4900	6800	5600	4700
	5300	6150	5100	4000	5950	4900	4000	6600	5600	4700	6400	5400	4500
	5500	6100	5000	4000	5900	4800	4000	6500	5450	4600	6300	5250	4400
	5700	6000	4900	4000	5800	4700	3950	6400	5300	4500	6200	5100	4300
	6100	5800	4700	4000	5600	4500	3800	6200	5100	4300	6000	4900	4100

FHB80-90(H)(/9)-E1

STANDARD SPECIFICATIONS PRELIMINARY

CHARACTERISTICS			TCM				
			FHB80/9-E1	FHB80H/9-E1	FHB90-E1	FHB90H-E1	
1.1	Manufacturer						
1.2	Manufacturer's model designation						
1.3	Power source: (battery, diesel, LPG, petrol)		Battery	Battery	Battery	Battery	
1.4	Operator type: pedestrian, (operator) - standing, - seated		Seated	Seated	Seated	Seated	
1.5	Load capacity	Q	(kg)	8000	8000	9000	9000
1.6	Load center distance	c	(mm)	900	900	600	600
1.8	Load wheel axle to fork face	x	(mm)	700	700	720	720
1.9	Wheelbase	y	(mm)	2550	2630	2550	2550
WEIGHT							
2.1	Truck weight without load, with maximum battery weight		kg	12095	14175	13425	13425
2.2	Axle loading with maximum load, front / rear (simple x mast, lowest lift height)		kg	18670 / 1425	20356 / 1819	20780 / 1645	20780 / 1645
2.3	Axle loading without load, front / rear (simple x mast, lowest lift height)		kg	6590 / 5505	7490 / 6685	7120 / 6305	7120 / 6305
WHEELS, DRIVE TRAIN							
3.1	Tyres: V = solid, L = pneumatic, SE = solid pneumatic - front / rear			SE	SE	SE	SE
3.2	Tyre dimensions, front			8.25-15	8.25-15	8.25-15	8.25-15
3.3	Tyre dimensions, rear			315 / 45-12	315 / 45-12	23x10-12	23x10-12
3.5	Number of wheels, front / rear (x = driven)			4x / 2	4x / 2	4x / 2	4x / 2
3.6	Track width (centre of tyres), front	b10	(mm)	1460	1460	1380	1380
3.7	Track width (centre of tyres), rear	b11	(mm)	1215	1215	1225	1225
DIMENSIONS							
4.1	Mast tilt, forwards / backwards	α / β	°	5.5 / 6	5.5 / 6	5.5 / 6	5.5 / 6
4.2	Height with mast lowered	h1	(mm)	2900	2900	2900	2900
4.3	Free lift	h2	(mm)	0	0	0	0
4.4	Lift height	h3	(mm)	3400	3400	3400	3400
4.5	Overall height with mast raised	h4	(mm)	4800	4800	4800	4800
4.7	Height to top of overhead guard	h6	(mm)	2420	2420	2420	2420
4.8	Seat height	h7	(mm)	1330	1330	1330	1330
4.12	Tow coupling height	h10	(mm)	465	465	465	465
4.19	Overall length	l1	(mm)	5340	5340	4880	4880
4.2	Length to fork face (includes fork thickness)	l2	(mm)	3740	3740	3680	3680
4.21	Overall width	b1 / b2	(mm)	1900	1900	1830	1830
4.22	Fork dimensions (thickness, width, length)	s / e / l	(mm)	200 x 60 x 1200	200 x 70 x 1600	200 x 60 x 1200	200 x 60 x 1200
4.23	Fork carriage iso 2328 / 30, FEM / A,B			4A	4A	5A	5A
4.24	Fork carriage width	b3	(mm)	1800	1800	1500	1500
4.31	Ground clearance under mast, with load	m1	(mm)	180	180	180	180
4.32	Ground clearance at center of wheelbase, (forks lowered)	m2	(mm)	165	165	165	165
4.33	Working aisle width with 1000 x 1200 mm pallets, crosswise	Ast	(mm)	5350	4955	5220	4975
4.34a	Working aisle width with 800 x 1200 mm pallets, load crosswise	Ast	(mm)	-	-	-	-
4.34b	Working aisle width with 800 x 1200 mm pallets, load lengthwise	Ast	(mm)	5550	5095	5420	5115
4.35	Turning circle radius	Wa	(mm)	3450	2950	3300	2950
4.36	Minimum distance between centres of rotation	b13	(mm)	1050	1150	1050	1050
PERFORMANCE							
5.1	Travel speed, with / without load		km / h	14 / 15	17 / 18	15 / 18	18 / 19
5.2	Lifting speed, with / without load		m / s	0.21 / 0.3	0.3 / 0.44	0.28 / 0.4	0.28 / 0.4
5.3	Lowering speed, with / without load		m / s	0.45 / 0.37	0.5 / 0.4	0.47 / 0.39	0.28 / 0.4
5.5	Rated drawbar pull, with / without load		N	5600 / 6300	5600 / 6300	6100 / 6850	6100 / 6850
5.6	Maximum drawbar pull, with / without load (5 min short duty)		N	20700 / 21500	20700 / 21500	15150 / 15900	23000 / 23900
5.7	Gradeability, with / without load		%	5 / 9.5	5 / 9	4.7 / 9	5.6 / 10
5.8	Maximum gradeability with / without load		%	9 / 15	9.2 / 16	7.7 / 12.7	10.3 / 17.8
5.9	Acceleration time (10 metres) with / without load		s	6.5 / 5	7 / 5.2	5.8 / 5.4	7.8 / 5.8
5.1	Service brakes (mechanical / hydraulic / electric / pneumatic)			hydraulic / electric	electric	electric	hydraulic / electric
ELECTRIC MOTOR							
6.1	Drive motor capacity (60 min. short duty)		kW	2 x 15	2 x 15	2 x 15	2 x 15
6.2	Lift motor output at 15% duty factor		kW	45	45	45	45
6.3	Battery to DIN 43 531 / 35 / 36 A / B / C / no			-	-	-	-
6.4	Battery voltage		V / Ah	96	96	96	96
6.5	Battery weight (including container)		kg	4300	4300	4300	4300
6.6a	Energy consumption according to DIN EN 16796		kWh / h	-	-	-	-
6.6b	Energy consumption acc. to VDI cycle		kWh / h	-	-	-	-
MISCELLANEOUS							
8.1	Type of drive control			inverter	inverter	inverter	inverter
10.1	Maximum operating pressure for attachments		bar	200	200	200	200
10.2	Oil flow for attachments		l / min	-	-	-	-
10.7	Noise level, value at operator's ear (EN 12053)		dB (A)	-	-	-	-
10.8	Towing coupling, type DIN 15170			72	72	72	72

DIMENSIONS FHB80-90(H)(9)-E1

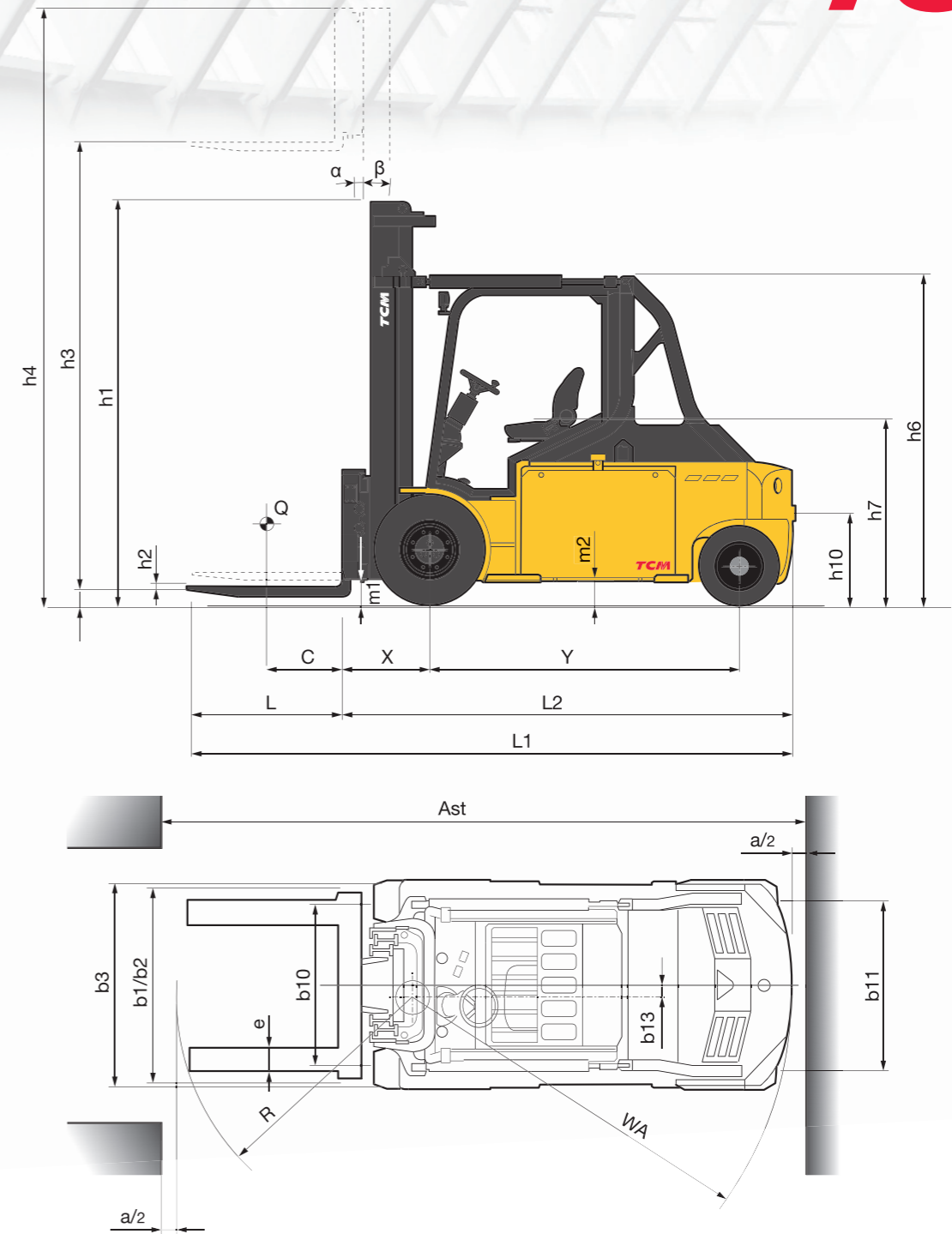

MAST LIFT HEIGHT CAPACITIES

	Max fork height (mm)	FHB80/9(H)-E1						FHB90(H)-E1					
		Sideshift			Side shifting fork positioner			Sideshift			Side shifting fork positioner		
		600	900	1200	600	900	1200	600	900	1200	600	900	1200
SINGLE stage mast	3400	8000	8000	6500	8000	8000	6500	9000	7200	5600	8800	7000	5600
	3800	8000	7800	6500	8000	7600	6300	8600	7100	5600	8400	6900	5600
	4200	8000	7700	6500	8000	7500	6300	8500	7000	5600	8300	6800	5500
	4600	8000	7600	6400	8000	7400	6200	8200	6800	5600	8000	6600	5500
	5500	8000	7200	6000	8000	7000	5800	7700	6400	5300	7500	6200	5100
DOUBLE and TRIPLE stage mast	3690	8000	7700	6500	8000	7500	6300	8100	6700	5500	7900	6500	5300
	5100	8000	7100	6050	8000	6900	5850	7300	6100	5100	7100	5900	4900
	5250	8000	7000	5950	8000	6800	5750	7150	6000	5000	6950	5800	4800
	5500	8000	6850	5800	8000	6650	5600	7000	5850	4850	6800	5650	4650
	5700	8000	6750	5700	7800	6650	5500	6800	5700	4700	6600	5500	4500

STANDARD SPECIFICATIONS PRELIMINARY

CHARACTERISTICS			TCM		
1.1	Manufacturer		FHB100-E1	FHB100H-E1	FHB120H-E1
1.2	Manufacturer's model designation		Battery	Battery	Battery
1.3	Power source: (battery, diesel, LPG, petrol)		Seated	Seated	Seated
1.4	Operator type: pedestrian, (operator) - standing, - seated		10000	10000	12000
1.5	Load capacity	Q (kg)	600	600	600
1.6	Load center distance	c (mm)	720	720	730
1.8	Load wheel axle to fork face	x (mm)	2630	2630	2980
1.9	Wheelbase	y (mm)			
WEIGHT					
2.1	Truck weight without load, with maximum battery weight	kg	14175	14425	16105
2.2	Axle loading with maximum load, front / rear (simple x mast, lowest lift height)	kg	20356 / 1819	22678 / 1747	26199 / 1906
2.3	Axle loading without load, front / rear (simple x mast, lowest lift height)	kg	7490 / 6685	7660 / 6765	8840 / 7265
WHEELS, DRIVE TRAIN					
3.1	Tyres: V = solid, L = pneumatic, SE = solid pneumatic - front / rear		SE	SE	SE
3.2	Tyre dimensions, front		300 - 15	300 - 15	355 / 65 - 15
3.3	Tyre dimensions, rear		315 / 45 -12	315 / 45 -12	315 / 45 - 12
3.5	Number of wheels, front / rear (x = driven)		4x / 2	4x / 2	4x / 2
3.6	Track width (centre of tyres), front	b10 (mm)	1460	1460	1565
3.7	Track width (centre of tyres), rear	b11 (mm)	1215	1215	1215
DIMENSIONS					
4.1	Mast tilt, forwards / backwards	α / β °	5.5 / 6	5.5 / 6	5.5 / 6
4.2	Height with mast lowered	h1 (mm)	2950	2950	2950
4.3	Free lift	h2 (mm)	0	0	0
4.4	Lift height	h3 (mm)	3400	3400	3400
4.5	Overall height with mast raised	h4 (mm)	4850	4850	4900
4.7	Height to top of overhead guard	h6 (mm)	2420	2420	2420
4.8	Seat height	h7 (mm)	1330	1330	1330
4.12	Tow coupling height	h10 (mm)	465	465	465
4.19	Overall length	l1 (mm)	4960	4960	5325
4.2	Length to fork face (includes fork thickness)	l2 (mm)	3760	3760	4125
4.21	Overall width	b1 / b2 (mm)	2000	2000	2140
4.22	Fork dimensions (thickness, width, length)	s / e / l (mm)	200 x 60 x 1200	200 x 60 x 1200	200 x 70 x 1200
4.23	Fork carriage iso 2328 / 30, FEM / A,B		5A	5A	pin-type
4.24	Fork carriage width	b3 (mm)	1800	1800	2000
4.31	Ground clearance under mast, with load	m1 (mm)	180	180	180
4.32	Ground clearance at center of wheelbase, (forks lowered)	m2 (mm)	165	165	165
4.33	Working aisle width with 1000 x 1200 mm pallets, crosswise	Ast (mm)	5420	5420	5705
4.34a	Working aisle width with 800 x 1200 mm pallets, load crosswise	Ast (mm)	-	-	-
4.34b	Working aisle width with 800 x 1200 mm pallets, load lengthwise	Ast (mm)	5420	5420	5905
4.35	Turning circle radius	Wa (mm)	3500	3500	3705
4.36	Minimum distance between centres of rotation	b13 (mm)	1250	1250	1250
PERFORMANCE					
5.1	Travel speed, with / without load	km / h	14 / 15	16 / 18	16 / 17
5.2	Lifting speed, with / without load	m / s	0.18 / 0.27	0.22 / 0.32	0.28 / 0.36
5.3	Lowering speed, with / without load	m / s	0.5 / 0.4	0.5 / 0.4	0.47 / 0.38
5.5	Rated drawbar pull, with / without load	N	5000 / 5600	5000 / 5650	5400 / 6800
5.6	Maxium drawbar pull,with / without load (5 min short duty)	N	18500 / 19000	18600 / 19350	22900 / 23700
5.7	Gradeability, with / without load	%	4 / 8	4.5 / 8	4.8 / 8.8
5.8	Maximum gradeability with / without load	%	8 / 14	8.3 / 14.5	8.7 / 15
5.9	Acceleration time (10 metres) with / without load	s	6 / 4	6.2 / 4.7	9.6 / 6.9
5.1	Service brakes (mechanical / hydraulic / electric / pneumatic)		hydraulic / electric	electric	electric
ELECTRIC MOTOR					
6.1	Drive motor capacity (60 min. short duty)	kW	2 x 15	2 x 15	2 x 15
6.2	Lift motor output at 15% duty factor	kW	45	45	45
6.3	Battery to DIN 43 531 / 35 / 36 A / B / C / no		-	-	-
6.4	Battery voltage	V / Ah	96	96	96
6.5	Battery weight (including container)	kg	4300	4300	4700
6.6a	Energy consumption according to DIN EN 16796	kWh / h	-	-	-
6.6b	Energy consumption acc. to VDI cycle	kWh / h	-	-	-
MISCELLANEOUS					
8.1	Type of drive control		inverter	inverter	inverter
10.1	Maximum operating pressure for attachments	bar	200	200	200
10.2	Oil flow for attachments	l / min	-	-	-
10.7	Noise level, value at operator's ear (EN 12053)	dB (A)	-	-	-
10.8	Towing coupling, type DIN 15170		72	72	72

DIMENSIONS FHB100-120(H)-E1

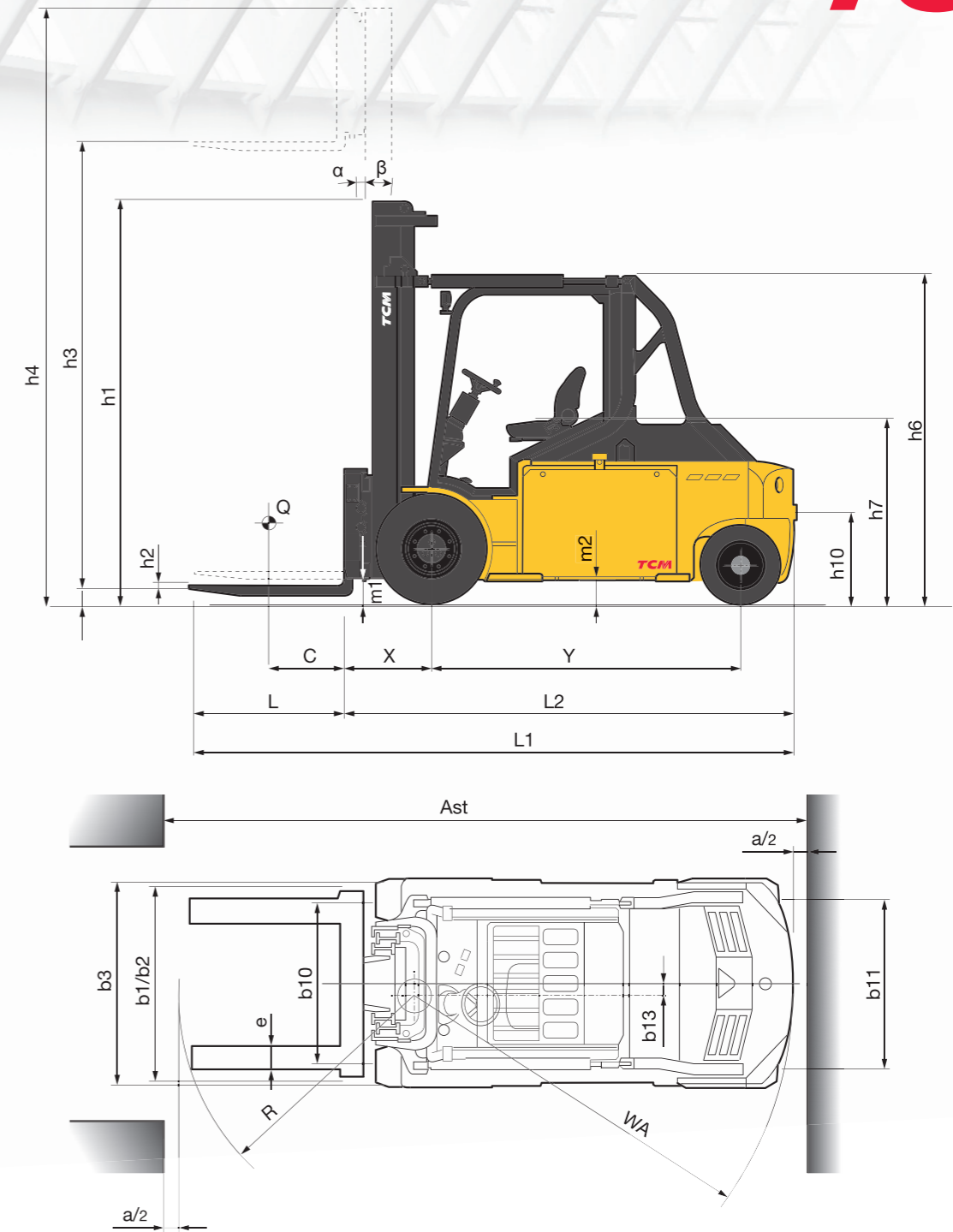

MAST LIFT HEIGHT CAPACITIES

Max fork height (mm)	FHB100(H)-E1						FHB120(H)-E1					
	Sideshift			Side shifting fork positioner			Sideshift			Side shifting fork positioner		
	Load Capacity (kgs) @ load centre (mm)											
	600	900	1200	600	900	1200	600	900	1200	600	900	1200
SINGLE stage mast	3400	10000	7450	5600	9800	7450	5600					
	3800	9700	7450	5600	9500	7450	5600					
	4200	9400	7450	5600	9200	7450	5600					
	4500	9200	7450	5600	9000	7400	5600					
	5500	8700	7200	5600	8500	7000	5600					
DOUBLE and TRIPLE stage mast	3730	8900	7400	5600	8700	7200	5600					
	5100	8000	6700	5600	7800	6500	5500					
	5300	7750	6550	5600	7550	6350	5400					
	5500	7600	6400	5500	7400	6200	5300					
	5700	7500	6300	5400	7300	6100	5200					

INFORMATION NOT AVAILABLE AT TIME OF PUBLICATION
PLEASE CONSULT WITH YOUR TCM DEALER REPRESENTATIVE
FOR FURTHER DETAILS

FHB60-120(H)(/9)E-1

STANDARD AND OPTIONS LIST

	FHB60-E1 FHB65-E1 FHB70-E1 FHB80-E1	FHB60H-E1 FHB65H-E1 FHB80H-E1	FHB70H-E1	FHB80H/9-E1	FHB90H-E1 FHB100H-E1 FHB120H-E1	FHB80/9-E1 FHB90-E1 FHB100-E1
GENERAL						
4-wheel chassis, 96 volts	●	●	●	●	●	●
Low overhead guard (Container version)	●	●	●	●	●	●
Key pre-set economy or high performance mode (ECO / PRO)	●	●	●	●	●	●
Variable hydraulic speed control functions	●	●	●	●	●	●
Intelligent curve control	●	●	●	●	●	●
Sensorised safety seat belt	●	●	●	●	●	●
CE name plates - language markings	●	●	●	●	●	●
Operations and Maintenance manual	●	●	●	●	●	●
POWER SOURCE						
Lead acid battery	●	●	●	●	●	●
FRAME						
Battery tray	●	●	●	●	●	●
Quick and easy battery lateral replacement	●	●	●	●	●	●
LIGHTING						
LED work lights	●	●	●	●	●	●
Amber strobe	●	●	●	●	●	●
'Blue point' rear light	●	●	●	●	●	●
'Blue point' rear light mounted low	●	●	●	●	●	●
ELECTRICAL SYSTEM						
Forward/Reverse drive direction selection with double pedal system	●	●	●	●	●	●
Drive direction lever in steering column (Forward-Neutral-Reverse)	●	●	●	●	●	●
Road light kit	●	●	●	●	●	●
PIN code access with start switch	●	●	●	●	●	●
Load weight indicator	●	●	●	●	●	●
OPERATOR'S CABIN						
Air conditioner	●	●	●	●	●	●
Heater	●	●	●	●	●	●
Multifunctional interactive full colour display	●	●	●	●	●	●
Rear view camera	●	●	●	●	●	●
Tilttable steering column	●	●	●	●	●	●
Fingertip control armrest	●	●	●	●	●	●
Manual control levers	●	-	●	●	-	●
Full-suspension vinyl Grammer MSG85 seat	●	●	●	●	●	●
ACCESSORIES						
Rear view mirror	●	●	●	●	●	●
External rear view mirror	●	●	●	●	●	●
Additional Camera	●	●	●	●	●	●
CABIN						
Standard overhead guard	●	●	●	●	●	●
Front screen and roof with wash / wiper	●	●	●	●	●	●
Low front screen and roof with wash / wiper	●	●	●	●	●	●
Heating element front screen	●	●	●	●	●	●
Heating element rear screen	●	●	●	●	●	●
Airconditioner	●	●	●	●	●	●
Plexi roof	●	●	●	●	●	●
PVC doors	●	●	●	●	●	●
Full cabin	●	●	●	●	●	●
EXTERIOR						
Special colour (RAL) for the frame and counterweight	●	●	●	●	●	●
FORKS & CARRIAGE						
Various fork lengths (1200 - 2400mm)	●	●	●	●	●	●
LOAD BACKREST						
Integrated side shift	●	●	●	●	●	●
Fork positioner+ integrated side shifter	●	●	●	●	●	●
Fork carriage with 8 rollers	●	●	●	●	●	●
HYDRAULIC SYSTEM						
3 / 4 / 5 - way valve armrest-mounted fingertip control	●	●	●	●	●	●
3 / 4 - way valve manual control	●	●	●	●	●	●
Double action FC 3 v, for clamp usage	●	●	●	●	●	●
Double action FC 4 v, for clamp usage	●	●	●	●	●	●
Double action MC 3 v, for clamp usage	●	-	-	-	-	●
Double action MC 4 v, for clamp usage	●	-	-	-	-	●
Hydraulic accumulator	●	●	●	●	●	●
3-way piping	●	●	●	●	●	●
4-way piping	●	●	●	●	●	●
TYRES						
Super elastic tyres	●	●	●	-	-	-
Non-marking super elastic tyres	●	●	●	-	-	-
Dual super elastic tyres	●	●	●	●	●	●
Non-marking solid tyres	●	●	●	●	●	●
Cushion tyres	●	●	●	●	●	●
Non-marking cushion tyres	●	●	●	●	●	●

KEY ● Standard ● Option - Not available

TCM
Always Evolving

info@tcm.eu | tcm.eu

Mitsubishi Logisnext Europe BV reserves the right to make any changes without notice concerning colours, equipment or specifications detailed in this brochure, or to discontinue individual models. The colours of vehicles delivered may differ slightly from those in this brochure. The specifications vary for different countries depending on local market conditions. Please consult your local dealer to ensure that the vehicle delivered accords with your expectations. All values are determined based on the standard condition and may vary, due to motor and system tolerances, condition of the truck and operational conditions. Some equipment shown on photos are optional. CEST2391-0923